

# aumüller

## Assembly and Commissioning Instructions

according to Machinery Directive 2006/42/EC (annex VI)

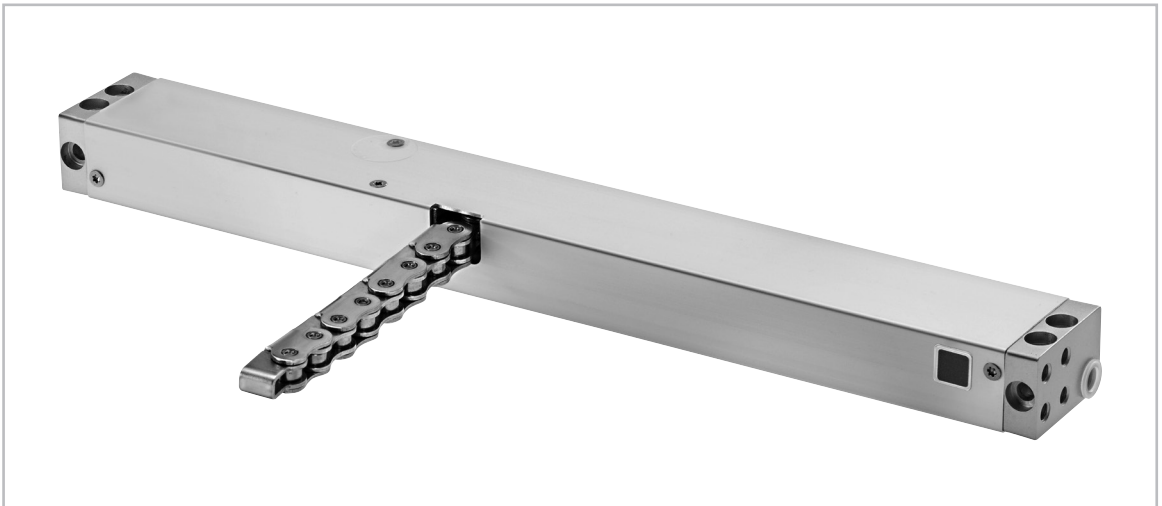

KS2 - CHAIN DRIVE FOR WINDOWS **CE**



01	<p>Abbreviations            Target Groups            Warning and Safety Symbols            Intended Use            Safety Instructions</p>	3 - 8
02	<p>Data sheet KS2 S2 (24V DC / 230V AC)            Data sheet KS2 S12 (24V DC / 230V AC)            Data sheet KS2 S12 230V AC Tandem-Set            Explanations of the product label and the „Z version“</p>	9 - 16
03	<p>Drive positioning: Symmetry or asymmetry            Overview: Growing variants and minimum sash heights            Additional order: drive chain with „chain stretched on one side“            Possible multiple operation</p>	16 - 19
04	<p><b>INSTALLATION STEP 1:</b> Inspection before the installation  <b>INSTALLATION STEP 2:</b> Installation prerequisite and Installation preparation</p>	20 - 21
05	<p><b>INSTALLATION STEP 3:</b> Determine casement brackets  <b>INSTALLATION STEP 4:</b> Determine frame brackets  <b>INSTALLATION STEP 5:</b> Hole layouts for frame brackets and casement brackets</p>	22 - 37
06	<p><b>INSTALLATION STEP 6A:</b> Rigid drive mounting on the window sash  <b>INSTALLATION STEP 6B + 6C:</b> Rigid drive mounting on the window frame  <b>INSTALLATION STEP 6D:</b> Rigid drive mounting on the transom</p>	38 - 43
07	<p><b>INSTALLATION STEP 7:</b> Cable routing  <b>INSTALLATION STEP 8A:</b> Covering of the drive  <b>INSTALLATION STEP 8B:</b> Installing the cover profile</p>	44 - 49
08	<p><b>INSTALLATION STEP 9:</b> Electric Connection  <b>INSTALLATION STEP 10:</b> Supply lines of the Control Unit to the drives  <b>INSTALLATION STEP 11:</b> Soft run mode  <b>INSTALLATION STEP 12:</b> Safety check and Test run            Help with malfunctions, repairs, maintenance, warranties</p>	50 - 56

## ABBREVIATIONS

### Index of abbreviations

These abbreviations are used consistently throughout these assembly & operating instructions. Unless stated differently, all dimensions indicated in this document are in mm. General tolerances in accordance with DIN ISO 2768-m.

A	drive
AK	connection cable / drive cable
AP	cover cap
BD	hinge
Fxxx	casement bracket
FAB	overall width of casement
FAH	overall height of casement
FG	casement weight
FL	casement
FÜ	casement overlap
HSK	main closing edge
Kxxx	frame bracket
L	construction length of drive
MB	central hinge
NRWG	NSHEV – natural smoke and heat exhaust ventilation
NSK	side closing edge
RA	frame
RAB	overall width of frame
RAH	overall height of frame
RWA	SHEV – smoke and heat exhaust ventilation
SL	snow load
→	opening direction

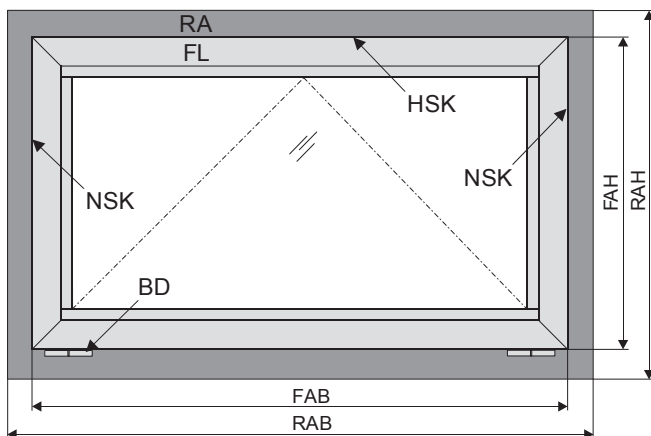

## TARGET GROUP

These instructions are intended for trained personnel and operators of systems for natural smoke ventilation (NRA / RWA) (natural smoke exhaust system / smoke and heat exhaust system) and natural ventilation via windows, who are knowledgeable of operating modes as well as the remaining risks of the system.

## WARNING AND SAFETY SYMBOLS IN THESE INSTRUCTIONS:

The symbols used in the instructions shall be strictly observed and have the following meaning:

 **DANGER** Failure to comply with the warning notes results in irreversible injuries or death.

 **WARNING** Failure to comply with the warning notes can result in irreversible injuries or death.

 **CAUTION** Failure to comply with the warning notes can result in minor or moderate (reversible) injuries.

**NOTE** Failure to comply with the warning notes can lead to damage to property.



**Caution / Warning**  
Danger due to electric current.



**Caution / Warning**  
Risk of crushing and entrapment during device operation (is provided as a sticker with the drive).



**Attention / Warning**  
Risk of damage to / destruction of drives and / or windows.

 **WARNING**

Once the assembly and commissioning has been completed, the installer of a machine „power-operated window and door“ shall hand these instructions over to the end-user. The end-user shall store these instructions in a safe place for further reference and use, if required.

 **WARNING**

This device is not intended for use by persons (including children) with physical, sensory or mental limitations or lacking experience and / or knowledge, unless they are supervised by a person who is responsible for the safety or were instructed by him on the usage of this equipment. Children should be supervised to ensure that they are not playing with this device.

Cleaning and operator's maintenance may not be performed by children without supervision.

**INTENDED USE**

**Area of application / Scope of application**

This drive is intended for the electromotive opening and closing of windows in facade and roof areas.

**The main task of this product**, in combination with a window and a suitable external control unit, **is to evacuate hot smoke and combustion gases in case of fire**, to save human lives and protect material assets. Furthermore, with the electromotive operated window and a suitable external control unit, **the natural ventilation** of the building can be ensured.

By attaching the drive to a movable element of the window a so-called "power-operated window" is created which, according to the Machinery Directive 2006 / 42 / EG, represents a machine.

**NOTE**

**Intended use according**

The drive is intended for stationary installation and electrical connection at the window as part of a building.

The drive is in combination with an external Control Unit (e.g. from **AUMÜLLER**) released for its proper use at a power-operated window for the following use:

- Application for natural ventilation
  - with an installation height of the drive and the bottom side of sash of at least 2,5 m above the floor, **or**
  - with an opening width at the HSK of the driven part of < 200 mm by a simultaneous speed of < 15 mm/s at the HSK in closing direction.
- Application as NRWG (natural smoke and heat exhaust ventilator(s) for ventilation without dual purpose for ventilation in accordance with EN12101-2.

Pay attention to possible hazards on tilting or rotating windows, whose secondary closing edges are located at less than 2,5 m installation height above the floor, under consideration of the Control Unit and usage!

**WARNING**

We as manufacturers are well aware of our duties and responsibilities regarding the development, manufacturing and placing of safe window drives on the market and consistently implement them. Ultimately, however, we have no direct influence on the usage of our drives. Therefore, as a precaution, we point out the following:

- The **constructor or his agent** (architect, specialist planner) **are obligated to evaluate the hazards to persons**, outgoing from the usage, installation position, opening parameters and from the external Control Unit of the power operated window, **already in the planning phase and to establish necessary protective measures.**
- The **constructor / manufacturer** of the machine "power-operated window" **must implement** the planned **protective measures** at the installation site or, if not yet established, **determine them** by it's own responsibility and detect or **minimize possible remaining risks.**

**The need for a risk assessment at the installation site due to the reasonably foreseeable misuse.**

**A risk assessment in accordance with the Machinery Directive 2006 / 42 / EG for the usage of the power-operated window for natural ventilation is absolutely necessary** under the following conditions:

- the installation height of the drive and lower edge of casement < 2,5 m above the floor **and** one of the following conditions:
- the opening width at the HSK > 200 mm, **or**
- the closing speed at the HSK is > 15 mm/s, **or**
- the opening speed at the HSK is > 50 mm/s, **or**
- the closing force at the HSK is > 150 N

The following flow chart can be applied, which also includes the protective measures in accordance with EN 60335-2-103/2016-05.

**Snow load on roof windows for RWA-systems**

Example:  
snow load = 60 kg

(Casement area x Typical snow load)

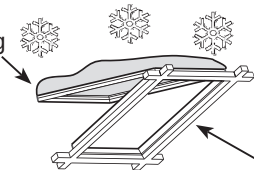

**Example calculation**

Establish snow loading based on national standards /directives  
(in Germany according to DIN 1055-5)

total weight = FG + snow load  
total weight = (40 kg + 60 kg) = 100 kg



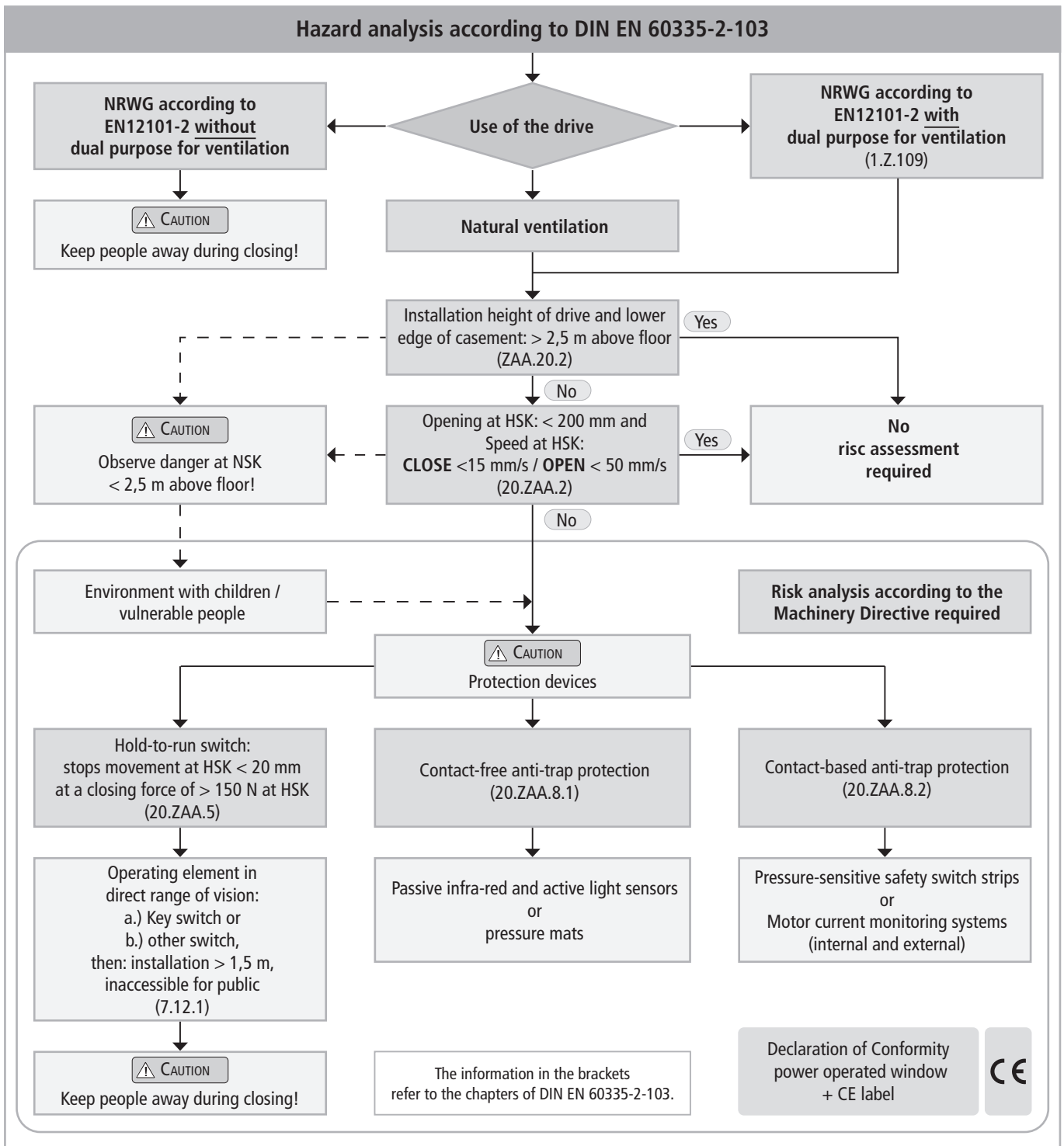

**Casement data**

Facade: bottom-hung window / top-hung window / side hung window  
 Roof: roof window / sky light  
 Opening direction: inward opening / outward opening  
 Profile material: aluminum, steel, plastic or wood.

The casement measurements supplied are only for orientation purposes. It is imperative that the **force-path diagram** of the drives are observed.

**NOTE**

When inspecting the drives for conformity with on-site requirements the following items must be observed:

- total weight of casement (glass + frame),
- additional loads: snow load / wind load (suction / pressure),
- casement size (FAB x FAH),
- side ratio FAB / FAH,
- installation / inclination angle,
- required opening area (geometric / aerodynamic),
- crosswind influences,
- driving force and stroke,
- mounting space at the window frame and casement frame.

**SAFETY INSTRUCTIONS**



It is important to follow these instructions for the safety of persons. These instructions shall be kept in a safe place for the entire service life of the products.

**Risk of crushing and entrapment!  
Window can close automatically!**

The integrated load cut-off stops the drive during closing and opening when the drive is overloaded.

**The compressive force is absolutely sufficient to crush fingers in case of carelessness.**



**Area of application**

The drive shall only be used according to its intended use. For additional applications consult the manufacturer or his authorized dealer.

Do not misuse the drive for other lifting operations!



Do not allow children to play with this drive or its electric controls, including the remote control!

Always check whether the system complies with current regulations. Special attention must be paid to the opening width, the opening area, the opening time and the opening speed of the window, the temperature range of the drives / external devices and cables as well as the cross section of the connecting cables as function of the cable length and power consumption.



All devices must be permanently protected from dirt and moisture, if the drive is not explicitly suitable for use in wet areas (see technical data).

**Installation**

These instructions address expert and safety-conscious electricians and / or qualified personnel knowledgeable in electrical and mechanical drive installation.



The safe operation, avoidance of injury to persons and damage to property, as well as risks, is only guaranteed by proper installation and setting according to these installation instructions.

All specifications for installation must be checked independently and, if necessary, adjusted at the installation site. The connection assignment, the electrical supply data (see product label) and performance limits (see technical data) as well as the mounting and installation instructions of the drive must be strictly observed and adhered to!



Never connect 24 V DC drives to 230 V AC mains voltage!  
**Danger to life!**

Do not reach into the window rabbet or the operating element (chain or spindle) during installation and operation! Ensure that, based on the installation position and the opening movement of the casement, persons cannot be trapped between the driven part of the window and surrounding fixed components (e.g. wall).

**Mounting material**

The required mounting material must fit with the drive and occurring load and, if necessary, supplemented.



Before installing the drive, check whether the casement is in good mechanical condition, the weight in balance and whether it opens and closes easily!

**Danger spots by crush and shear points**

<p>Side-hung</p>	<p>Bottom-hung</p>	<p>Roof windows / skylight domes</p>	<p>Louvre windows</p>
<p>○ Danger spots: crush and shear points according to DIN EN 60335-2-103</p>			

### Crush and shear points

To avoid injuries, **crushing and shear points** between casement and frame must be secured **against entrapment up to an installation height of 2,5 meters above the floor** with appropriate measures. This can be achieved e.g. by using contact-based or contactless protective devices against entrapment, which stop the motion through contact or through interruption by a person. At a force higher than 150 N at the main closing edge the motion must stop within 20 mm. A warning symbol at the opening element must indicate this clearly.

### Unintentional or independent opening or falling

Casements are to be hinged or secured such way that in case one of the mounting elements fails it will not crash / slam down or move in an uncontrolled manner by e.g. using double suspensions, safety scissors, casement stays. Tilting windows shall be equipped with safety scissors or similar devices to avoid damages and risks of injury for persons through improper installation and operation. The safety scissors must be adjusted to the opening stroke of the drive (see technical data) to avoid blocking. The opening width of the safety scissors must be bigger than the drive stroke.



**WARNING**

The movable casement must be secured against unintentional or independent opening as well as falling down.

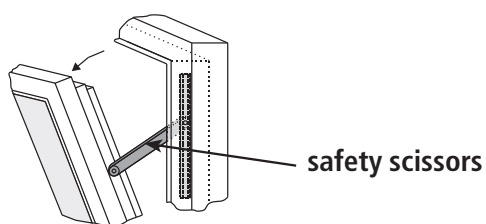

### Routing cables and electrical connection

Routing or installing of electrical cables and connections may be performed only by specialist companies. Never operate drives, control units, operating elements and sensors at operating voltages and connections contrary to the specifications of the manufacturer. All relevant national instructions shall be observed for the installation.



All-pole disconnecting devices shall be installed in the permanent electrical installation or external Control Unit for the drive. The mains supply lines 230 V / 400 V AC shall be protected separately!



24V DC drives may only be connected to power supply sources that comply with SELV specifications.

**NOTE**

In the case of tandem / multiple operation of drives connected in series, the cross-section of the connection cable must be checked autonomously, depending on the total current consumption of the drive system.



**WARNING**

Damaged mains supply lines of drives with plug connectors may only be replaced by the manufacturer or qualified service / maintenance personnel! Power cables which are fixed to the drive casing cannot be replaced. If the cable is damaged the device must be scrapped!

The types of cable, cable lengths and cross-sections shall be selected in accordance with the manufacturer's technical data. If necessary, the cable types shall be coordinated with the competent local authorities and energy supply companies. Low-voltage lines (24 V DC) shall be routed separate from the high-voltage lines. Flexible cables may not be flush-mounted. Freely suspended cables shall be equipped with strain reliefs.



Cables must be laid such way that they cannot be sheared off, twisted or bent during operation. Drive cables laid inside window profiles must be protected by insulating tubes with a sufficient temperature resistance. Through holes shall be equipped with cable sleeves!

Clamping points shall be checked for tightness of threaded connections and cable ends. Access to junction boxes, clamping points and external drive control boxes shall be ensured for maintenance work.

**Commissioning, operation and maintenance**

After the installation and after each modification in the set up all functions shall be checked with a trial run. It shall be ensured that drive and casement are set correctly and that security systems, if available, are functioning properly.

**After the installation of the system is completed the end-user shall be instructed in all important operating steps.** If necessary, he must be advised of all remaining risks / dangers.

The end-user shall be specifically instructed that no additional forces, except pushing and pulling forces in the opening and closing direction of the casement, may be applied to the spindle, chain or lever of the drive.

**NOTE** Post warning signs!

During the proper assembly of drives with mounting elements at a window, and the connection to an external control unit, the interfaces resulting from mechanical and electrical performance characteristics of single elements shall be observed.

**CAUTION** Other persons must be kept away from the casement when a hold-to-run switch (pushbutton) is operated or when a window, which has been opened by a smoke and heat exhaust system, is closing!

**CAUTION** The operating element of hold-to-run switches must be installed within direct view from the window, but apart from moving elements. If the switch is not a key-operated switch it must be installed at a minimum height of 1,5 m and inaccessible to the public!

**CAUTION** Do not allow children to play with permanently mounted control devices and keep remote controls out of reach for children!

**WARNING** During cleaning, maintenance work and while exchanging parts the drive must be completely disconnected from the power supply and secured against unintentional reactivation.

**WARNING** Do not actuate the drive or the casement when repair or re-setting works are performed!

**Replacement parts, fasteners and controls**

The drive shall only be operated with control devices from the same manufacturer. There is no liability, warranty or customer service if third-party parts are used. Exclusively original spare parts of the manufacturer shall be used for mounting elements or expansions.

**Ambient conditions**

The product may not be subjected to impacts or falls, or to vibrations, moisture, aggressive vapors or other harmful environments, unless the manufacturer released it for one or more of these environmental conditions.

- **Operation:**  
 Ambient temperature: -5 °C ... +60°C  
 Relative humidity: < 90% less 20°C;  
 < 50% less 40°C;  
 no formation of condensation

**NOTE** Observe temperature range during installation!

**NOTE** We recommend the use of wind and rain sensors in order to avoid weather-related damages to drives, windows and buildings thru open window sashes.

- **Transport / Storage:**  
 Storage temperature: -5°C ... +40°C  
 Relative humidity: < 60%

**Accident prevention regulations and workmen's compensation insurance guidelines**

For work on or in a building or building part the provisions and instructions of the respective accident prevention regulations (local workmen's compensation insurance guidelines) shall be observed and adhered to.

**Declaration of Conformity and of Incorporation**

The drive is manufactured and inspected in accordance with European guidelines. The respective Declaration of Conformity and of Incorporation is on hand.

**In case that the use of the drive differs from the intended use, a risk evaluation for the power operated window shall be performed and a Declaration of Conformity according Machinery Directive 2006 / 42 / EG issued.**

24V

DATA SHEET KS2 S2 24V DC R / L

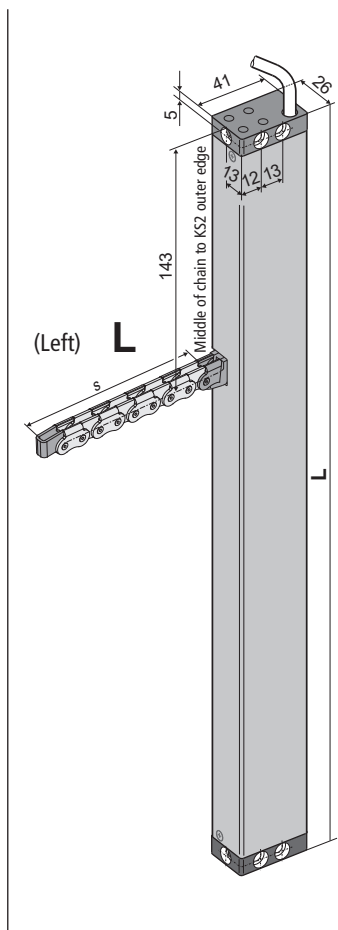
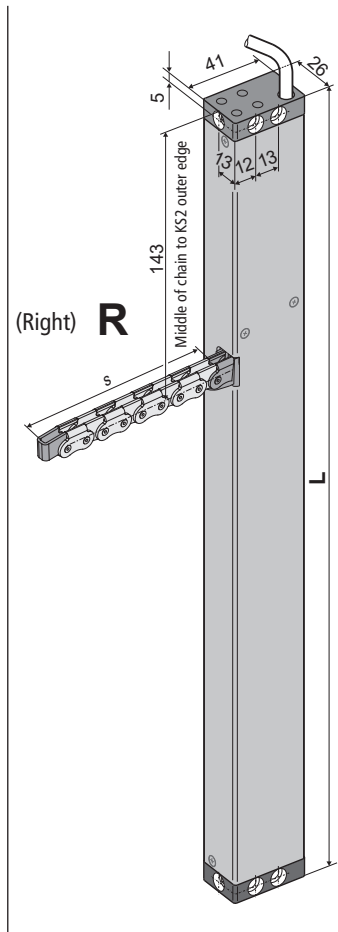

- Application: Natural ventilation as single drive
- Internal load dependent cut-off switch S2 in OPEN / CLOSE direction



TECHNICAL DATA

$U_N$	Rated voltage	24V DC (19 V ... 28 V)
$I_N$	Rated current	0,5 A
$I_A$	Cut-off current	0,7 A
$P_N$	Rated power	12 W
DC	Duty cycle	5 cycles (ED 30 % - ON: 3 min. / OFF: 7 min.)
	Protection rating	IP 32
	Ambient temperature range	-5 °C ... +60 °C
$F_Z$	Pulling force max.	200 N
$F_A$	Pushing force max.	100 N
		<p><math>s &gt; 600</math> mm only for pulling application</p>
$F_H$	Pullout force	1.800 N (fastening depended)
	Chain	Stainless steel, without protruding rivet heads. Simple connection to casement brackets. Small bending radii allow maximum opening angles of small windows.
	Connecting cable	non-halogen, grey 3 x 0,5 mm <sup>2</sup> , ~ 3 m
$v$	Speed	$\curvearrowright$ 10,0 mm/s $\curvearrowleft$ 10,0 mm/s
$s$	Stroke	50 – 800 mm
$L$	Length	see order data
	Sound pressure level:	≤ 70 dB (A)

ORDER DATA

s [mm]	L [mm]	Version	Finish	PU/pcs.	Part.-No.
200	335	KS2 200 S2 24V R (right)	E6/C-0	1	521120
		KS2 200 S2 24V L (left)	E6/C-0	1	521420
300	380	KS2 300 S2 24V R (right)	E6/C-0	1	521130
		KS2 300 S2 24V L (left)	E6/C-0	1	521430
400	430	KS2 400 S2 24V R (right)	E6/C-0	1	521140
		KS2 400 S2 24V L (left)	E6/C-0	1	521440
500	545	KS2 500 S2 24V R (right)	E6/C-0	1	521150
		KS2 500 S2 24V L (left)	E6/C-0	1	521450
600	545	KS2 600 S2 24V R (right)	E6/C-0	1	521160
		KS2 600 S2 24V L (left)	E6/C-0	1	521460
800	625	KS2 800 S2 24V R (right)	E6/C-0	1	521180
		KS2 800 S2 24V L (left)	E6/C-0	1	521480

DATA SHEET KS2 S2 230V AC R / L

230V

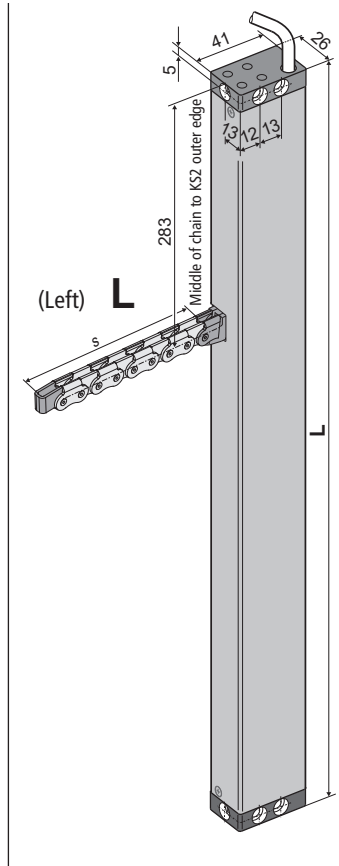
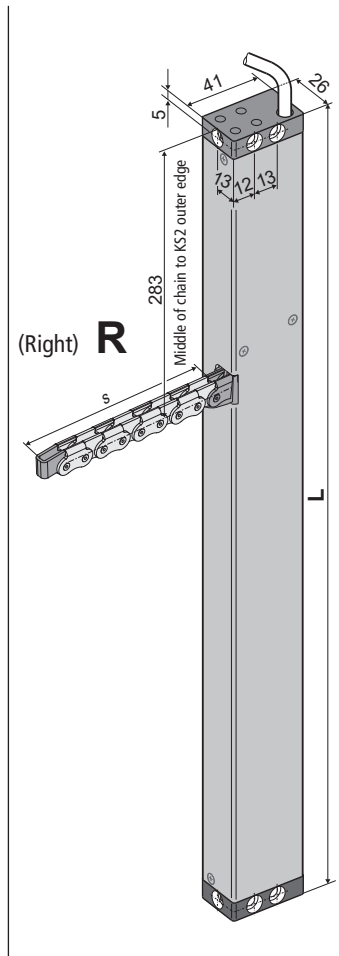

- Application: Natural ventilation as single drive
- Internal load dependend cut-off switch S2 in OPEN / CLOSE direction
- Parallel connection up to 8 drives in one group

TECHNICAL DATA

$U_N$	Rated voltage	230V AC (50 Hz)
$I_N$	Rated current	0,13 A
$I_A$	Cut-off current	0,2 A
$P_N$	Rated power	30 W
DC	Duty cycle	5 cycles (ED 30 % - ON: 3 min. / OFF: 7 min.)
	Protection rating	IP 32
	Ambient temperature range	-5 °C ... +60 °C
$F_z$	Pulling force max.	200 N
$F_A$	Pushing force max.	
		s > 600 mm only for pulling application
$F_H$	Pullout force	1.800 N (fastening depended)
	Chain	Stainless steel, without protruding rivet heads. Simple connection to casement brackets. Small bending radii allow maximum opening angles of small windows.
	Connecting cable	non-halogen, grey 6 x 0,75 mm <sup>2</sup> , ~ 3 m
v	Speed	10,0 mm/s  10,0 mm/s
s	Stroke	50 – 800 mm
L	Length	see order data
	Sound pressure level:	≤ 70 dB (A)

ORDER DATA

s [mm]	L [mm]	Version	Finish	PU/pcs.	Part.-No.
200	475	KS2 200 S2 230V R (right)	E6/C-0	1	494920
		KS2 200 S2 230V L (left)	E6/C-0	1	494720
300	520	KS2 300 S2 230V R	E6/C-0	1	494930
		KS2 300 S2 230V L	E6/C-0	1	494730
400	570	KS2 400 S2 230V R	E6/C-0	1	494940
		KS2 400 S2 230V L	E6/C-0	1	494740
500	685	KS2 500 S2 230V R	E6/C-0	1	494950
		KS2 500 S2 230V L	E6/C-0	1	494750
600	685	KS2 600 S2 230V R	E6/C-0	1	494960
		KS2 600 S2 230V L	E6/C-0	1	494760
800	765	KS2 800 S2 230V R	E6/C-0	1	494980
		KS2 800 S2 230V L	E6/C-0	1	494780

DATA SHEET KS2 S12 24V DC R / L



- Application: natural ventilation, RWA, ferralux®-NRWG
- Internal Intelligent Control Electronics S12
- Z-Version: Programmable feedback limit position „OPEN“ or „CLOSE“ (max. 24V, 500 mA)

**Options**

- Programmable special functions
- M-COM for automatic synchronised run of multi-drive systems and automatic sequence control with locking drives (S3 / S12)

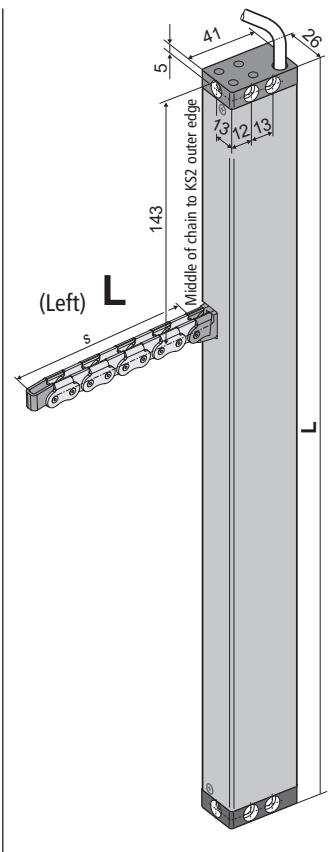
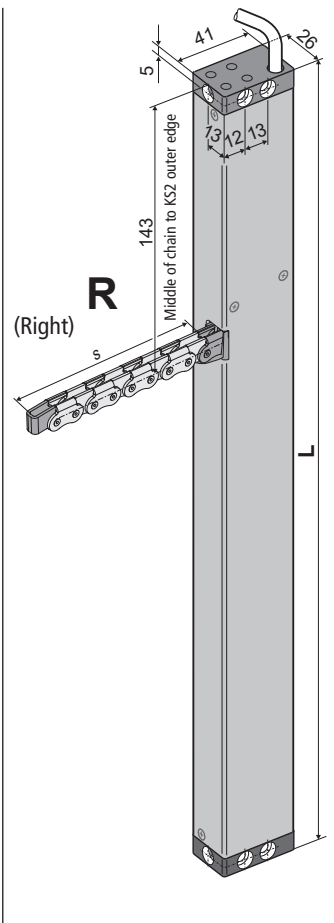

**TECHNICAL DATA**

<b>U<sub>N</sub></b>	Rated voltage	24V DC (19 V ... 28 V)
<b>I<sub>N</sub></b>	Rated current	0,7 A
<b>I<sub>A</sub></b>	Cut-off current	1,0 A
<b>P<sub>N</sub></b>	Rated power	17 W
<b>DC</b>	Duty cycle	5 cycles (ED 30 % - ON: 3 min. / OFF: 7 min.)
	Protection rating	IP 32
	Ambient temperature range	-5 °C ... +60 °C
<b>F<sub>Z</sub></b>	Pulling force max.	250 N
<b>F<sub>A</sub></b>	Pushing force max.	250 N

F (N)	s (mm)
250	200
250	300
200	400
150	500
100	600
50	800
50	1000

**Zug Pull**

**Schub Push**

s > 600 mm only for pulling application

<b>F<sub>H</sub></b>	Pullout force	1.800 N (fastening depended)									
	Chain	Stainless steel, without protruding rivet heads. Simple connection to casement brackets. Small bending radii allow maximum opening angles of small windows.									
	Connecting cable	non-halogen, grey 3 x 0,5 mm <sup>2</sup> , ~ 3 m non-halogen, grey 5 x 0,5 mm <sup>2</sup> , ~ 3 m (Z-Version)									
<b>v</b>	Speed	<table border="0"> <tr> <td>s ≤ 400</td> <td>↖ 8,0 mm/s</td> <td>↘ 8,0 mm/s</td> </tr> <tr> <td>s &gt; 400 – 600</td> <td>↖ 12,0 mm/s</td> <td>↘ 8,0 mm/s</td> </tr> <tr> <td>s &gt; 600</td> <td>↖ 13,5 mm/s</td> <td>↘ 8,0 mm/s</td> </tr> </table>	s ≤ 400	↖ 8,0 mm/s	↘ 8,0 mm/s	s > 400 – 600	↖ 12,0 mm/s	↘ 8,0 mm/s	s > 600	↖ 13,5 mm/s	↘ 8,0 mm/s
s ≤ 400	↖ 8,0 mm/s	↘ 8,0 mm/s									
s > 400 – 600	↖ 12,0 mm/s	↘ 8,0 mm/s									
s > 600	↖ 13,5 mm/s	↘ 8,0 mm/s									
<b>s</b>	Stroke	50 – 1000 mm									
<b>L</b>	Length	see order data									
	Sound pressure level:	≤ 70 dB (A)									



**ORDER DATA**

s [mm]	L [mm]	Version	Finish	PU/pcs.	Part.-No.
200	335	KS2 200 S12 24V R (right)	E6/C-0	1	521620
		KS2 200 S12 24V R Z	E6/C-0	1	521623
		KS2 200 S12 24V L (left)	E6/C-0	1	521720
		KS2 200 S12 24V L Z	E6/C-0	1	521723
300	380	KS2 300 S12 24V R (right)	E6/C-0	1	521630
		KS2 300 S12 24V R Z	E6/C-0	1	521633
		KS2 300 S12 24V L (left)	E6/C-0	1	521730
		KS2 300 S12 24V L Z	E6/C-0	1	521733
400	430	KS2 400 S12 24V R (right)	E6/C-0	1	521640
		KS2 400 S12 24V R Z	E6/C-0	1	521643
		KS2 400 S12 24V L (left)	E6/C-0	1	521740
		KS2 400 S12 24V L Z	E6/C-0	1	521743
500	545	KS2 500 S12 24V R (right)	E6/C-0	1	521650
		KS2 500 S12 24V R Z	E6/C-0	1	521653
		KS2 500 S12 24V L (left)	E6/C-0	1	521750
		KS2 500 S12 24V L Z	E6/C-0	1	521753
600	545	KS2 600 S12 24V R (right)	E6/C-0	1	521660
		KS2 600 S12 24V R Z	E6/C-0	1	521663
		KS2 600 S12 24V L (left)	E6/C-0	1	521760
		KS2 600 S12 24V L Z	E6/C-0	1	521763
800	625	KS2 800 S12 24V R (right)	E6/C-0	1	521680
		KS2 800 S12 24V R Z	E6/C-0	1	521683
		KS2 800 S12 24V L (left)	E6/C-0	1	521780
		KS2 800 S12 24V L Z	E6/C-0	1	521783



DATA SHEET KS2 S12 230V AC R / L

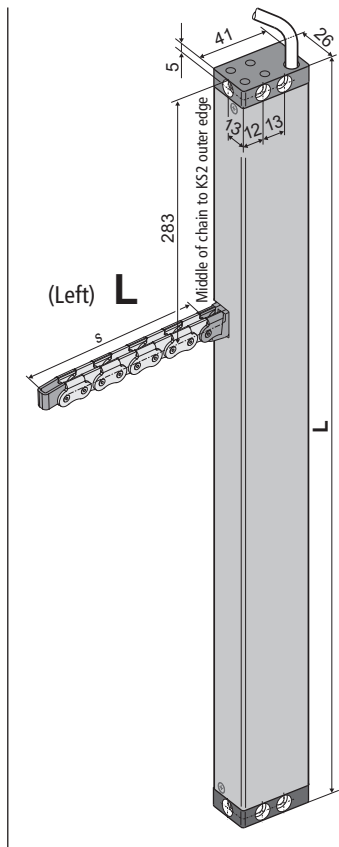
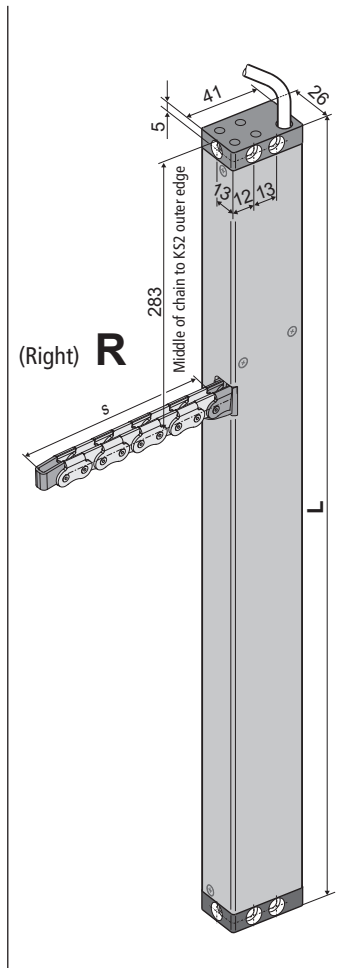

- Application: natural ventilation
- Internal Intelligent Control Electronics S12
- Parallel connection up to 8 drives in one group
- Z-Version: Programmable feedback limit position „OPEN“ or „CLOSE“ (max. 24V, 500 mA)

**Options**

- Programmable synchronised run (max. 4 drives) and special functions (Attention: not possible with Z-version)

**TECHNICAL DATA**

<b>U<sub>N</sub></b>	Rated voltage	230V AC (50 Hz)
<b>I<sub>N</sub></b>	Rated current	0,13 A
<b>I<sub>A</sub></b>	Cut-off current	0,2 A
<b>P<sub>N</sub></b>	Rated power	30 W
<b>DC</b>	Duty cycle	5 cycles (ED 30 % - ON: 3 min. / OFF: 7 min.)
	Protection rating	IP 32
	Ambient temperature range	-5 °C ... +60 °C
<b>F<sub>Z</sub></b>	Pulling force max.	250 N
<b>F<sub>A</sub></b>	Pushing force max.	250 N
	<b>F<sub>H</sub></b> Pullout force	1.800 N (fastening depended)
	Chain	Stainless steel, without protruding rivet heads. Simple connection to casement brackets. Small bending radii allow maximum opening angles of small windows.
	Connecting cable	non-halogen, grey 6 x 0,75 mm <sup>2</sup> , ~ 3 m
<b>v</b>	Speed	↖ 8,0 mm/s ↗ 8,0 mm/s
<b>s</b>	Stroke	50 – 1000 mm
<b>L</b>	Length	see order data
	Sound pressure level:	≤ 70 dB (A)

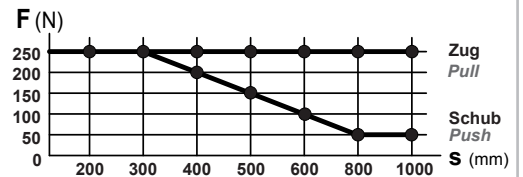

s > 600 mm only for pulling application

ORDER DATA

s [mm]	L [mm]	Version	Finish	PU/pcs.	Part.-No.
200	475	KS2 200 S12 230V R (right)	E6/C-0	1	494020
		KS2 200 S12 230V R Z	E6/C-0	1	494023
		KS2 200 S12 230V L (left)	E6/C-0	1	494120
		KS2 200 S12 230V L Z	E6/C-0	1	494123
300	520	KS2 300 S12 230V R (right)	E6/C-0	1	494030
		KS2 300 S12 230V R Z	E6/C-0	1	494033
		KS2 300 S12 230V L (left)	E6/C-0	1	494130
		KS2 300 S12 230V L Z	E6/C-0	1	494133
400	570	KS2 400 S12 230V R (right)	E6/C-0	1	494040
		KS2 400 S12 230V R Z	E6/C-0	1	494043
		KS2 400 S12 230V L (left)	E6/C-0	1	494140
		KS2 400 S12 230V L Z	E6/C-0	1	494143
500	685	KS2 500 S12 230V R (right)	E6/C-0	1	494050
		KS2 500 S12 230V R Z	E6/C-0	1	494053
		KS2 500 S12 230V L (left)	E6/C-0	1	494150
		KS2 500 S12 230V L Z	E6/C-0	1	494153
600	685	KS2 600 S12 230V R (right)	E6/C-0	1	494060
		KS2 600 S12 230V R Z	E6/C-0	1	494063
		KS2 600 S12 230V L (left)	E6/C-0	1	494160
		KS2 600 S12 230V L Z	E6/C-0	1	494163
800	765	KS2 800 S12 230V R (right)	E6/C-0	1	494080
		KS2 800 S12 230V R Z	E6/C-0	1	494083
		KS2 800 S12 230V L (left)	E6/C-0	1	494180
		KS2 800 S12 230V L Z	E6/C-0	1	494183

EXPLANATIONS ON THE PRODUCT LABEL

The product label informs about:

- manufacturer's address
- article reference number and name
- technical characteristics
- date of manufacturing with firmware version
- certifications
- serial number

**NOTE** Never install and operate damaged products.

In the event of any complaints, please indicate the product serial number (SN) (see product label).

Exemplary representation

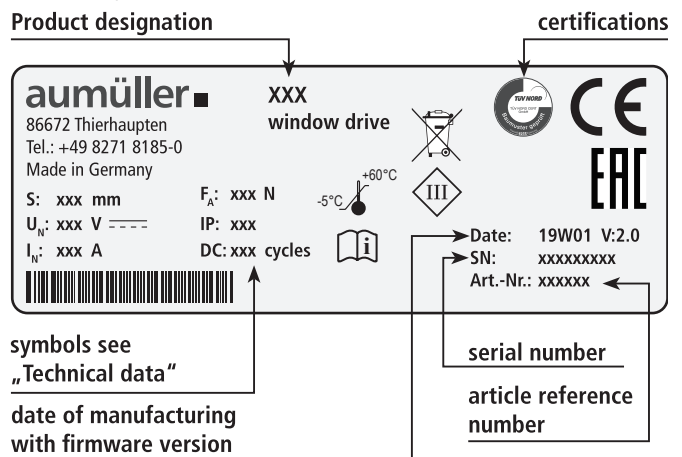

EXPLANATIONS ON THE VERSION „Z“ (FOR EXAMPLE KS2 600 S12 24V Z)

Drives with version „Z“ (e.g. KS2 600 S12 24V Z) have an additional volt free contact with connection for an external signal monitoring.

The volt free contact (max. 24V, 500mA) is open when the drive is in **CLOSED** position.

DATA SHEET KS2 S12 230V AC TANDEM-SET

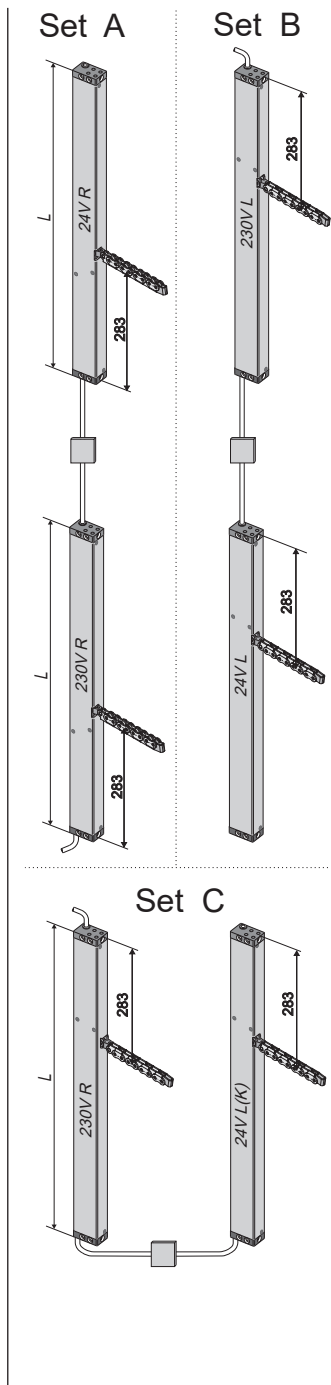

- Application: natural ventilation
- Factory-configured set includes:
  - Master: KS2 xxx S12 230V AC R/L with voltage output 24V DC
  - Slave: KS2 xxx S12 24V DC R/L with connection cable on the motor side  
KS2 xxx S12 24V DC L-K with connection cable on the chain side

- Parallel connection up to 8 sets of drives in one group
- Junction box to be site supplied

**Options:**

- Programmable special functions and sequence control with locking drives (S3 / S12)
- Screw terminal connections in drive housing upon request

**TECHNICAL DATA**

<b>U<sub>N</sub></b>	Rated voltage	230V AC (50 Hz)																		
<b>I<sub>N</sub></b>	Rated current	0,15 A																		
<b>I<sub>A</sub></b>	Cut-off current	0,2 A																		
<b>P<sub>N</sub></b>	Rated power	35 W																		
<b>DC</b>	Duty cycle	5 cycles (ED 30 % - ON: 3 min. / OFF: 7 min.)																		
	Protection rating	IP 32																		
	Ambient temperature range	-5 °C ... +60 °C																		
<b>F<sub>Z</sub></b>	Pulling force max.	2 x 250 N																		
<b>F<sub>A</sub></b>	Pushing force max.																			
		<table border="1"> <caption>Force vs Stroke Data</caption> <thead> <tr> <th>Stroke (mm)</th> <th>Zug (N)</th> <th>Schub (N)</th> </tr> </thead> <tbody> <tr> <td>200</td> <td>500</td> <td>500</td> </tr> <tr> <td>300</td> <td>500</td> <td>450</td> </tr> <tr> <td>400</td> <td>500</td> <td>350</td> </tr> <tr> <td>500</td> <td>500</td> <td>200</td> </tr> <tr> <td>600</td> <td>500</td> <td>100</td> </tr> </tbody> </table>	Stroke (mm)	Zug (N)	Schub (N)	200	500	500	300	500	450	400	500	350	500	500	200	600	500	100
Stroke (mm)	Zug (N)	Schub (N)																		
200	500	500																		
300	500	450																		
400	500	350																		
500	500	200																		
600	500	100																		
		s > 600 mm only for pulling application																		
<b>F<sub>H</sub></b>	Pullout force	1.800 N (fastening depended)																		
	Chain	Stainless steel, without protruding rivet heads. Simple connection to casement brackets. Small bending radii allow maximum opening angles of small windows.																		
	Connecting cable	Master: non-halogen, grey 6 x 0,75 mm <sup>2</sup> , ~ 3 m 3 x 0,5 mm <sup>2</sup> , ~ 3 m Slave: non-halogen, grey 3 x 0,5 mm <sup>2</sup> , ~ 3 m																		
<b>v</b>	Speed	8,0 mm/s  8,0 mm/s																		
<b>s</b>	Stroke	50 – 1000 mm																		
<b>L</b>	Length	see order data																		
	Sound pressure level:	≤ 70 dB (A)																		

ORDER DATA				
s [mm]	L [mm]	Version	PU / pcs.	Part.-No.
200	475	KS2 200 S12 230V Set A (R/R)	1	494220
		KS2 200 S12 230V Set B (L/L)	1	494320
		KS2 200 S12 230V Set C (R / L-K)	1	494420
300	520	KS2 300 S12 230V Set A (R/R)	1	494230
		KS2 300 S12 230V Set B (L/L)	1	494330
		KS2 300 S12 S 230V et C (R / L-K)	1	494430
400	570	KS2 400 S12 230V Set A (R/R)	1	494240
		KS2 400 S12 230V Set B (L/L)	1	494340
		KS2 400 S12 230V Set C (R / L-K)	1	494440

ORDER DATA				
s [mm]	L [mm]	Version	PU / pcs.	Part.-No.
500	685	KS2 500 S12 230V Set A (R/R)	1	494250
		KS2 500 S12 230V Set B (L/L)	1	494350
		KS2 500 S12 230V Set C (R / L-K)	1	494450
600	685	KS2 600 S12 230V Set A (R/R)	1	494260
		KS2 600 S12 230V Set B (L/L)	1	494360
		KS2 600 S12 230V Set C (R / L-K)	1	494460
800	765	KS2 800 S12 230V Set A (R/R)	1	494280
		KS2 800 S12 230V Set B (L/L)	1	494380
		KS2 800 S12 230V Set C (R / L-K)	1	494480

24V

230V

**OPTIONS**

Special model	PU/pcs.	Part.-No.
<b>Drive housing painted in RAL colours</b>		
<b>Lump sum for coating</b>		<b>516030</b>
Specify at order stage:	1 – 20	<b>516004</b>
	21 – 50	<b>516004</b>
	51 – 100	<b>516004</b>
	ab 101	<b>516004</b>
<b>For 24V drives: Extension of the standard connection cable length to:</b>		
5 m – non-halogen, grey – 3 x 0,5 mm <sup>2</sup>		<b>501034</b>
10 m – non-halogen, grey – 3 x 0,5 mm <sup>2</sup>		<b>501036</b>
5 m – non-halogen, grey – 5 x 0,5 mm <sup>2</sup>		<b>501054</b>
10 m – non-halogen, grey – 5 x 0,5 mm <sup>2</sup>		<b>501056</b>
<b>For 230V drives: Extension of the standard connection cable length to:</b>		
5 m – non-halogen, grey – 6 x 0,75 mm <sup>2</sup>		<b>501164</b>
10 m – non-halogen, grey – 6 x 0,75 mm <sup>2</sup>		<b>501166</b>
<b>For 24V drives: Microprocessor programming S12</b>		
Electronic stroke reduction 24V S12		<b>524190</b>
Programming drives 24V / 230V S12		<b>524180</b>
<b>For 230V drives: Microprocessor programming S12</b>		
Programming synchronised multi-drive systems 230V S12		<b>495588</b>
Electronic stroke reduction (drives 230V AC)		<b>495590</b>
Programming drives 24V / 230V S12		<b>524180</b>
<b>Optional accessories for drives with S12</b>		
M-COM Configuration module for synchronised multi-drive systems	1	<b>524177</b>

**DRIVE POSITIONING: SYMMETRY OR ASYMMETRY**

**Drive positioning: Symmetrical**

Symmetrical linkage of casement bracket or frame bracket should always be preferred to an asymmetrical one.

**Advantage:**

- for a Tandem drive application, combination of drives in R / L version can be used
- uniform force transmission to the window
- uniform casement pressure (tightness)

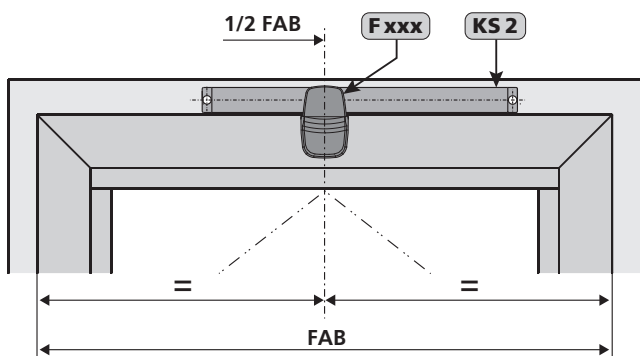

**Drive positioning: Asymmetrical**

Asymmetrical linkage of casement bracket or frame bracket can be used in case of lack of space on the window frame / casement.

**Check:**



- unequal force transmission to the window
- window statics allows unequal force distribution
- unequal casement pressure (tightness)

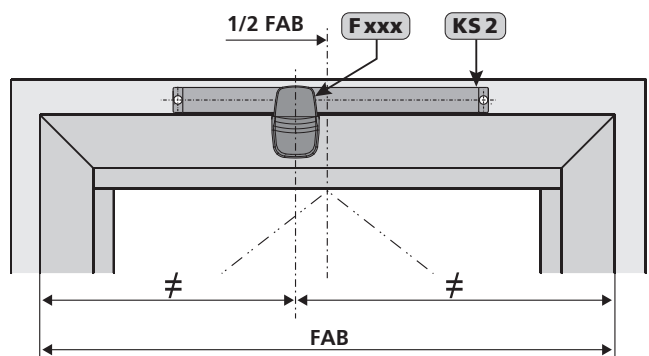

OVERVIEW: GROWING VARIANTS AND MINIMUM SASH HEIGHTS

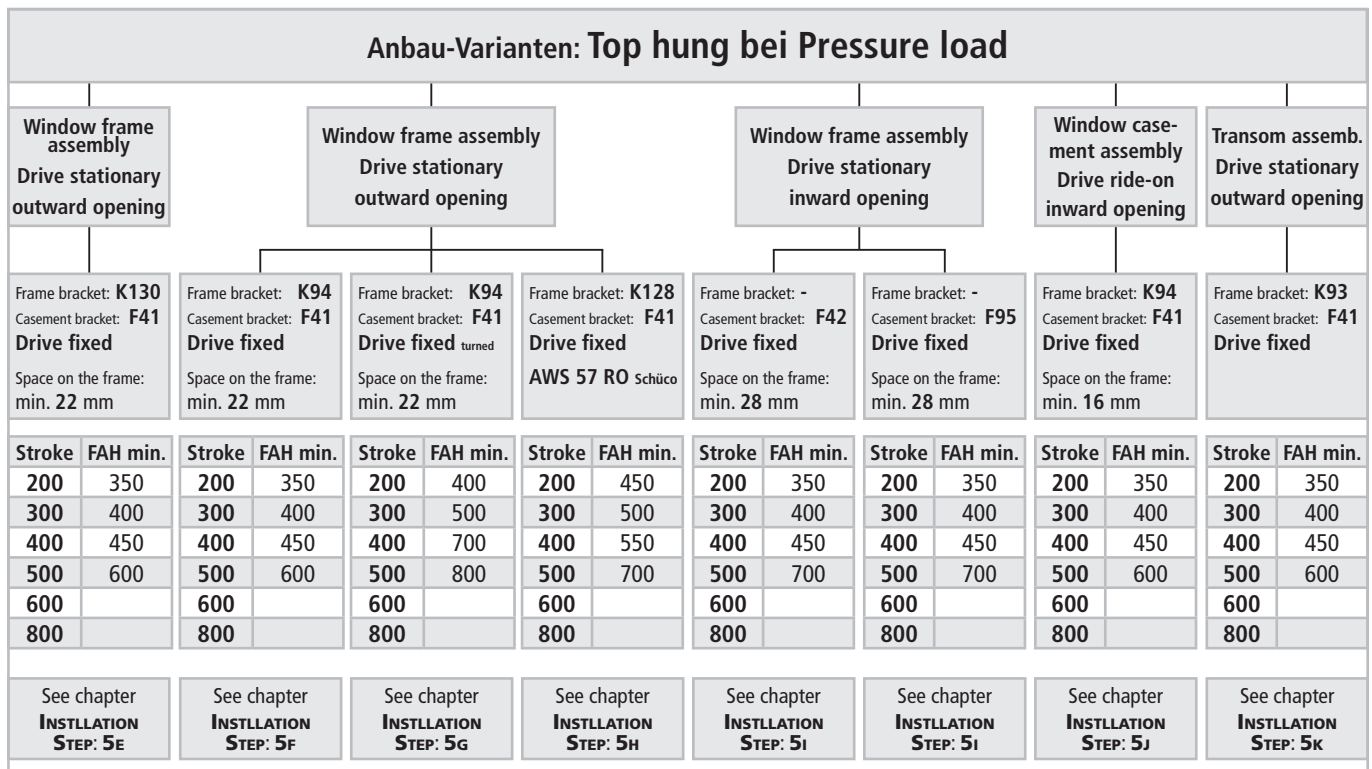
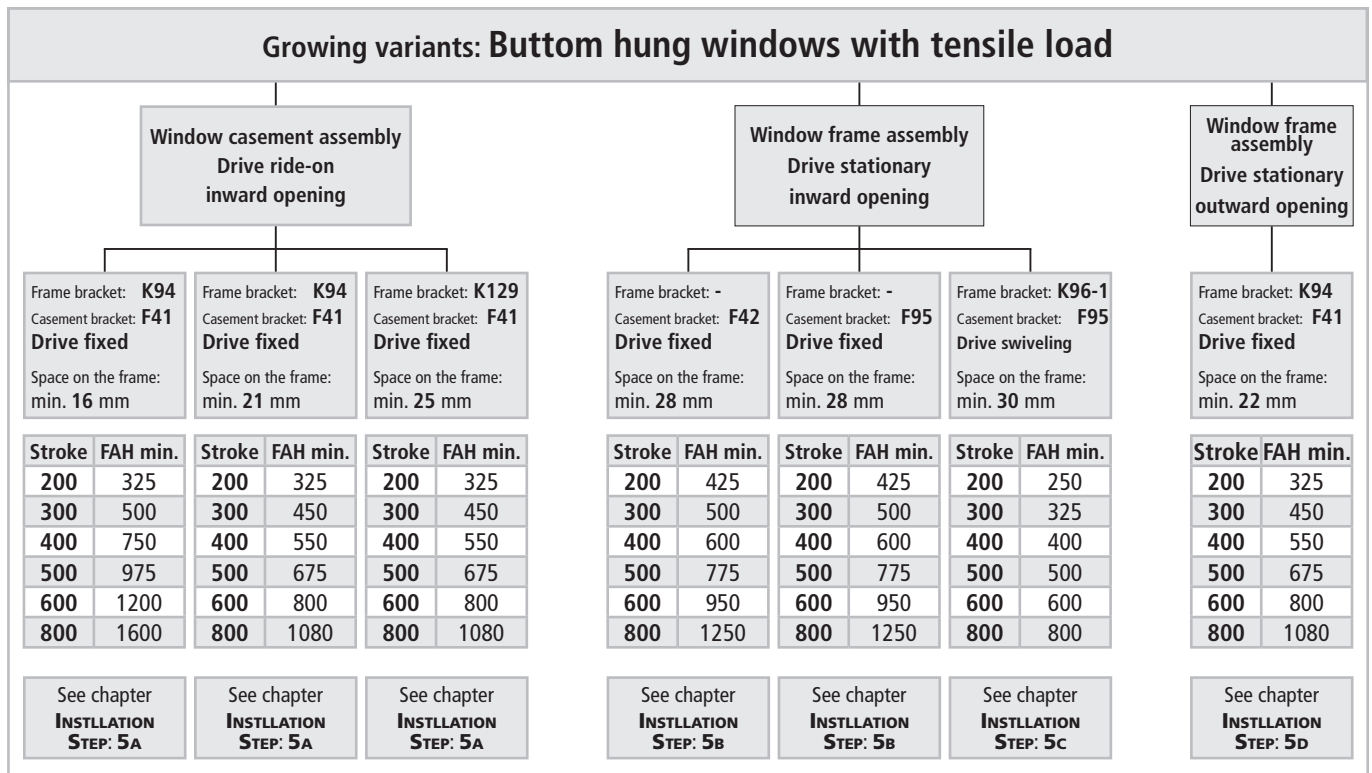

**Values are determined in:**  
 Casement weight: max. 30 kg/m<sup>2</sup>  
 Casement width: max. 1200 mm (with 1 drive)  
 Window overlap: 10 mm

03

**ADDITIONAL ORDER: FOR DRIVE CHAIN WITH „CHAIN STRETCHED ON ONE SIDE“ ON SIDE-HUNG WINDOWS**

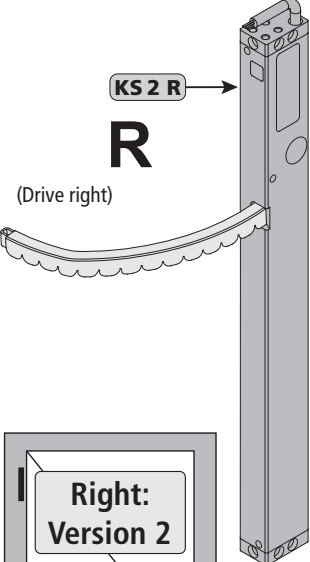
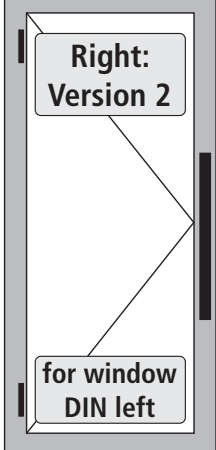
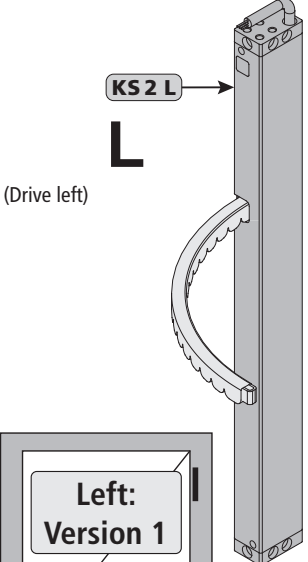
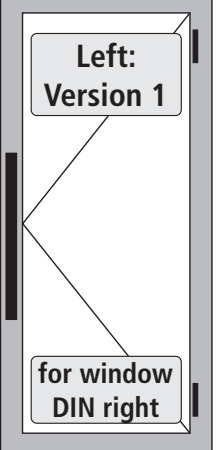

**Additional order**

<p style="text-align: center;"><b>Right: Version 2</b> for window DIN left</p> <p style="text-align: center;"><b>Part.-No. 521524</b> chain stretched on one side</p> <div style="text-align: center;">  <p><b>KS 2 R</b> <b>R</b> (Drive right)</p> </div> <div style="text-align: center; margin-top: 20px;">  <p><b>Right: Version 2</b> for window DIN left</p> </div>	<p style="text-align: center;"><b>Left: Version 1</b> for window DIN right</p> <p style="text-align: center;"><b>Part.-No. 521526</b> chain stretched on one side</p> <div style="text-align: center;">  <p><b>KS 2 L</b> <b>L</b> (Drive left)</p> </div> <div style="text-align: center; margin-top: 20px;">  <p><b>Left: Version 1</b> for window DIN right</p> </div>
--	---

**Side-hung window with chain stretched on one side**

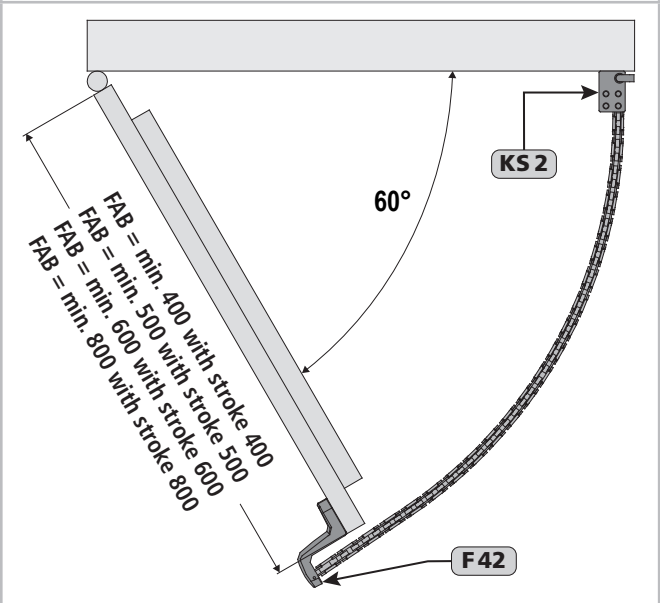
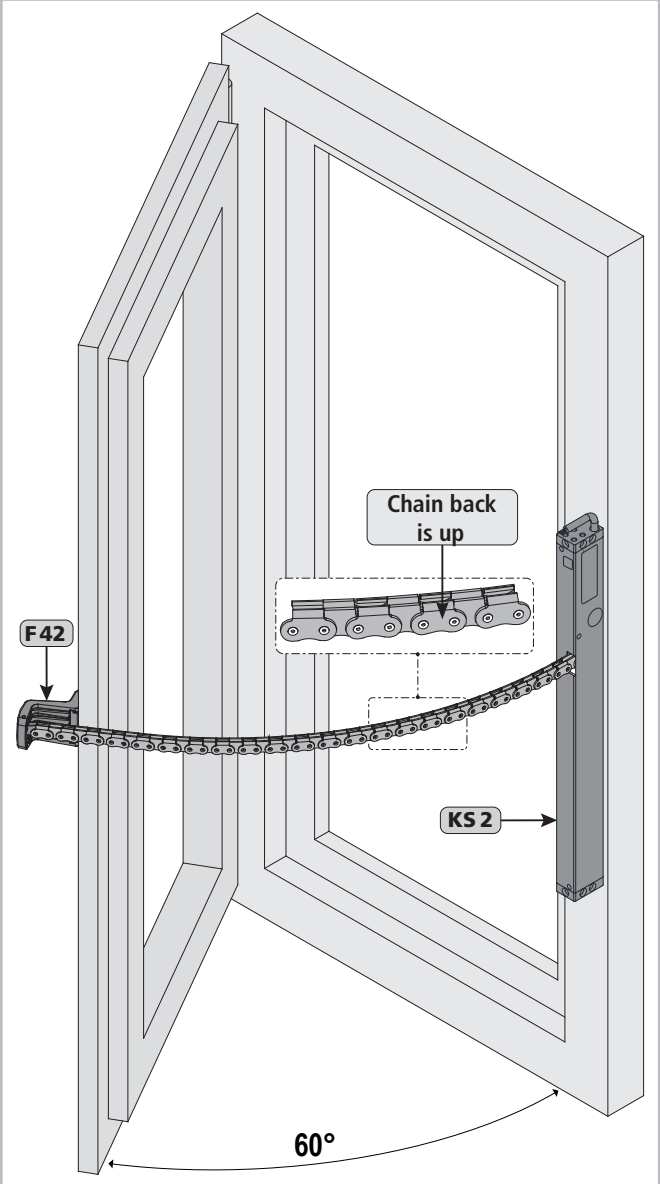

**Minimum overall width of casement (FAB) at side-hung windows**

Window frame assembly Drive stationary inward opening	Window casement assembly Drive ride-on inward opening
Frame bracket: -	Frame bracket: K94
Casement bracket: F42	Casement bracket: F41
Drive: fix	Drive: fix
Space on the frame: min. 28 mm	Space on the frame: min. 21 mm

Stroke	FAB min.	Opening angle	Stroke	FAB min.	Opening angle
400	400	~ 60°	400	400	~ 60°
500	500	~ 60°	500	500	~ 60°
600	600	~ 60°	600	600	~ 60°

**Additional order required!**

Part.-No. 521524 - drive „Right“ for window DIN left  
 Part.-No. 521526 - drive „Left“ for window DIN right

03

POSSIBLE MULTI-DRIVE OPERATING WITH M-COM

24V

230V

Possible multiple operation of KS2 S12 in 24V DC with M-COM

24V

Multi-drive operating

Version: Right

Multi-drive operating

Version: Left

Configuration multi-drive operating with M-COM

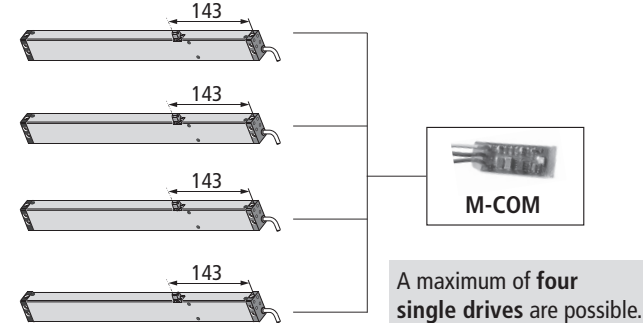

Configuration multi-drive operating with M-COM

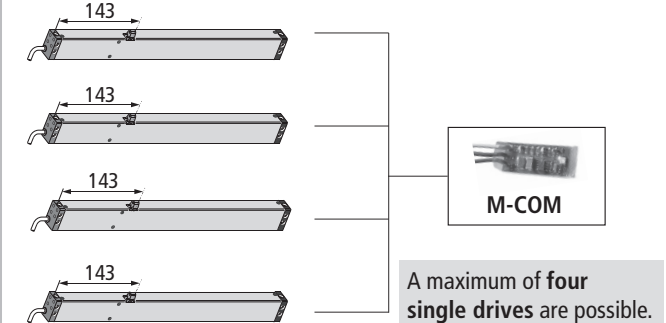

Multi-drive operating

Combination: Right + Left

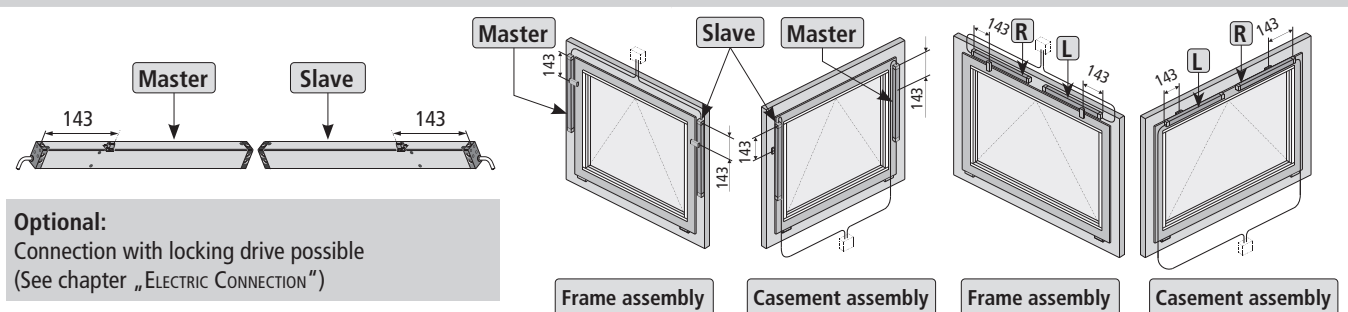

Possible multiple operation bei KS2 S12 in 230V AC

230V

Multi-drive operating

Set A (Version: Right)

Multi-drive operating

Set B (Version: Left)

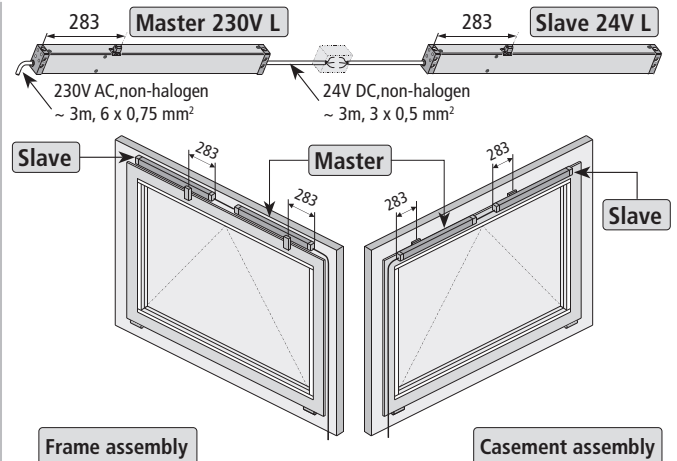
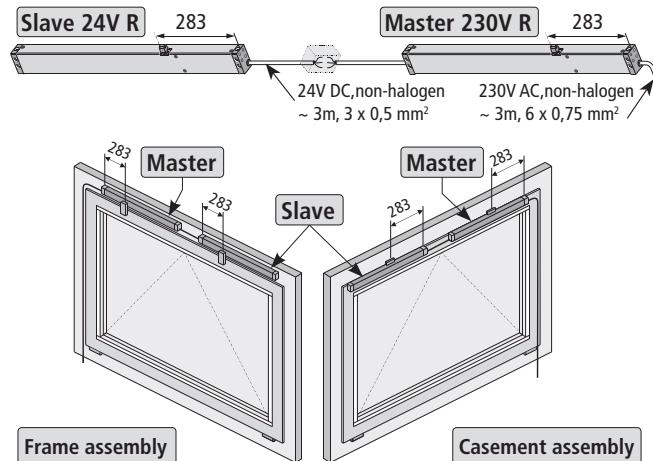

Multi-drive operating

Set C (Combination: Master R + Slave L (K))

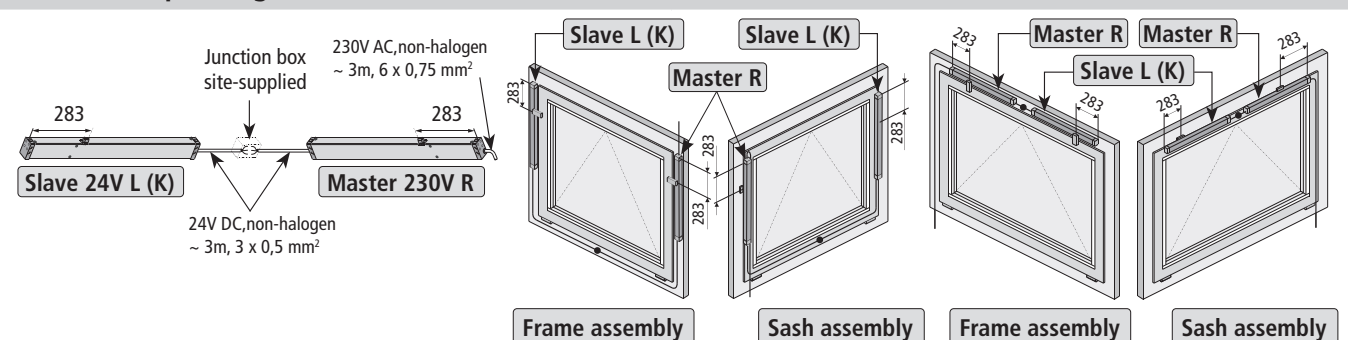



## INSTALLATION STEP 1: INSPECTION BEFORE THE INSTALLATION



Important instructions for a safe installation. Observe all instructions, wrong installation may result in serious injury!

### Storage of drives at the construction site

Protective measures against damages, dust, moisture or contamination shall be taken. Store drives intermediately only in dry and well ventilated rooms.

### Inspection of drives before installation

Check drives and window before installation for good mechanical condition and completeness. The chains / spindles of the drives must be extendable or retractable easily. The casement must run smoothly and the weight must be in balance.

### NOTE

We recommend the use of our test kit for the inspection of drives with the rated voltage 24V= / 230V~ (see table below). Damaged products may not be operated under any circumstance.

#### Test kit for drives

<b>Order number:</b>	533981
<b>Application:</b>	Test kit to check running direction and communication of drives 24V DC or 230V AC (including batteries)
<b>Supply voltage:</b>	230V AC
<b>Drive types:</b>	24V DC / 230V AC
<b>Drive current:</b>	max. 3 A
<b>Display:</b>	drive current, battery charge
<b>Ambient temperature:</b>	-5 °C ... + 40 °C
<b>Plastic housing:</b>	250 x 220 x 210 mm
<b>Weight:</b>	approx. 3,6 kg
<b>Feature / equipment:</b>	Control elements: 2 switches + 1 button

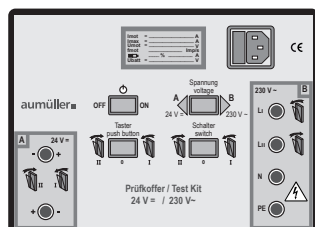

The test procedure of drives may only be performed on a non-slip and secured mat or a test fixture. During the test run the test element must not be interfered with. The test may only be conducted by or under the supervision of expert personnel.

For testing chain drives the chain must be extended and retracted at an angle of approx. 90°. The spindle tubes of spindle drives in round housing tubes must be secured against independent spinning before starting the test to avoid deviations in the integrated position encoder.

### Inspection of the intended use

The planned use of the drive must be checked for compliance with its intended use. If used otherwise the liability and warranty claim expires.

### Predictable misuse

It is imperative that foreseeable misuse of drives is avoided! Here are a few examples:

- do not connect 24 V DC drives to a 230 V AC mains voltage,
- observe synchronous run and sequence control by drives with multiple interconnection (if existing),
- use drives only indoors,
- avoid additional force influences, e.g. transverse forces.

### Testing mechanical requirements

Prior to the start of the installation check whether :

- the support surface and the profile static for the load transmission is sufficient,
- a support construction for the secure fastening of the drives is required,
- cold bridges (thermal separation) are avoidable at action points,
- there is sufficient space for the swivel movement of the drive.

If not, counter measures must be taken!



The support surface of the frame brackets or casement brackets must rest completely on the window or frame profile. There must be no tilting of the fastening elements during extension and retraction of the drives. A safe and solid fastening must be ensured at the window profile.



It is imperative that the sufficiently mechanical stiffness of the fastener type as well as of the swivel range of the drive is observed.

If this is not guaranteed another type of fastening or another type of drive must be selected.



## INSTALLATION STEP 2: INSTALLATION PREREQUISITE AND INSTALLATION PREPARATION

The following conditions must be fulfilled for the installation of the drives so they can be properly assembled with other parts and constructed to a complete machine at the window without impairing the safety and health of persons:

1. The design of the drive must fulfill the requirements.
2. The fastening accessories (casement brackets or frame brackets) must fit the window profile; the profile-dependent hole lay-out must be complied with.
3. The space required for the installation of the drive on the frame and casement profile must be sufficient.
4. The window must be in perfect mechanical condition before the installation. It should open and close easily.
5. The fastening material for the installation of the drive must fit the window material (see table).

Wood windows	Wood screws: i.e. DIN 96, DIN 7996, DIN 571  round head with slot, round head with cross, hex head, special type
steel, stainless steel, aluminum windows	Self-tapping screws, thread screws, sheet-metal screws i.e. ISO 4762, ISO 4017, ISO 7049, ISO 7085, DIN 7500  cylinder head with hex socket, internal serration (Torx), Phillips head or external hex head  blind rivet nut
plastic windows	Screws for plastic i.e. DIN 95606, DIN 95607, ISO 7049, ISO 7085, DIN 7500  round head with cross, external hex head, Torx

Recommendation:  
if possible, screw through two cavity webs

### Tools required

- Marker,
- Grains,
- Hammer,
- Screwdriver (slotted-head, cross or Torx) size by site conditions,
- Hexagonal wrench size 3 / 4 / 5 / 6,
- Torque wrench,
- Power drill,
- Threadlock adhesive,
- possibly a tool for blind rivet nuts (size 6).

### Check window data on site

- Measure FAB and FAH.
- Check / calculate weight of casement.  
If unknown, it can be determined approximately with the following formula:

$$G \text{ (Casement weight) [kg]} = \frac{FAB \text{ [m]} * FAH \text{ [m]} * \text{Glass thickness [mm]} * 2,5 * 1,1}{\text{glass-density} * \text{frame share}}$$

- Check / calculate the required drive force and compare with drive data. If unknown, it can be determined approximately with the following formula:

$$F \text{ [N]} = \frac{5,4 * G \text{ [kg]} * s \text{ [m]}}{a \text{ [m]}}$$

Facade

$$F \text{ [N]} = \frac{5,4 * G \text{ [kg]} * FAH \text{ [m]}}{a \text{ [m]}}$$

Roof

- a = Distance of action point to hinges
- F = Drive force
- s = Stroke

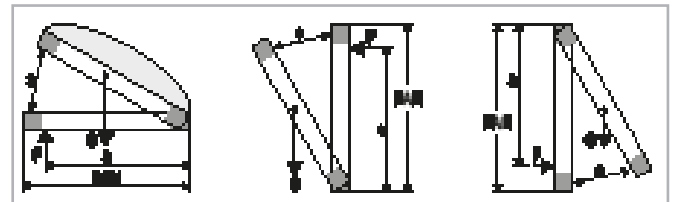

### Scope of delivery:

Prior to assembly, check items quantity in the delivery for completeness.

#### Accessories for chain drive

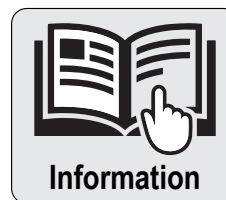

Assembly and Commissioning Instructions for chain drives (german / english)



Warning sign sticker „Risk of entrapment“ (1x)

**INSTALLATION STEP 3: DETERMINE CASEMENT BRACKETS**

Hole layouts for casement brackets		
<p><b>Casement bracket F17</b></p> <p>use with K105</p>	<p><b>Casement bracket F18</b></p> <p>use with K105</p>	<p><b>Casement bracket F18-1</b></p> <p>use with K105</p>
<p><b>Casement bracket F19</b></p> <p>use with K105</p>	<p><b>Casement bracket F20</b></p> <p>use with K105</p>	<p><b>Casement bracket F21</b></p> <p>K128, K130</p>
<p><b>Casement bracket F35</b></p> <p>use with K93, K94, K129, K130</p>	<p><b>Casement bracket F37</b></p> <p>use with K93, K94, K129, K130</p>	<p><b>Casement bracket F41</b></p> <p>use with K93, K94, K129</p>
<p><b>Casement bracket F42</b></p>	<p><b>Casement bracket F95</b></p> <p>use with K96</p>	

05

**INSTALLATION STEP 4: DETERMINE FRAME BRACKETS**

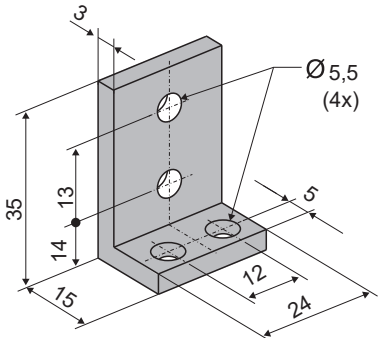
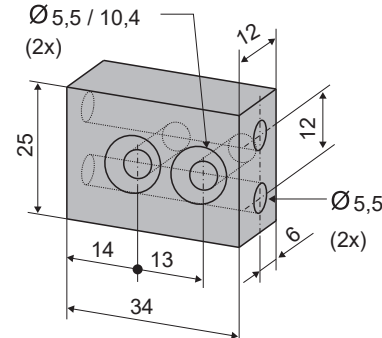
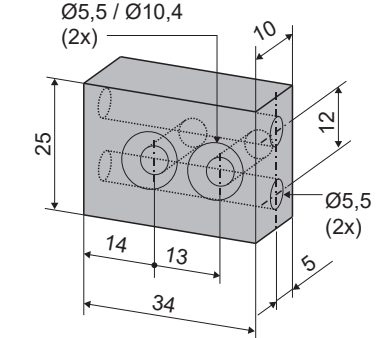
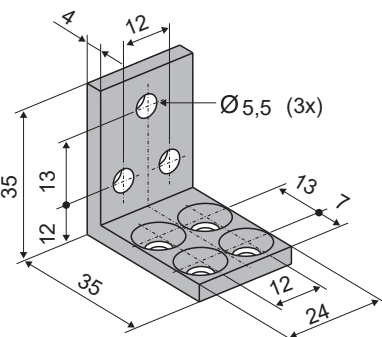
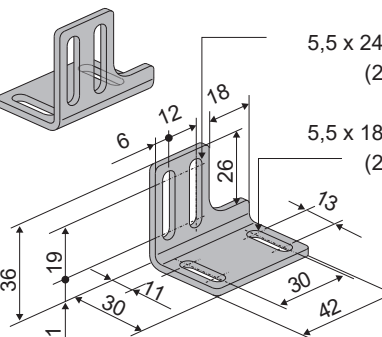
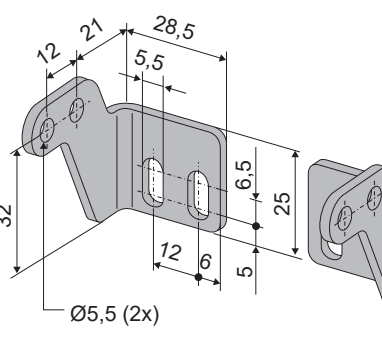
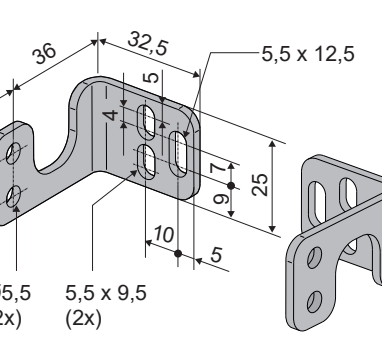
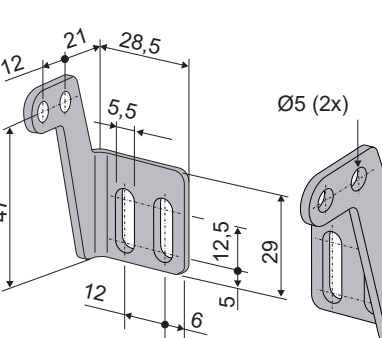
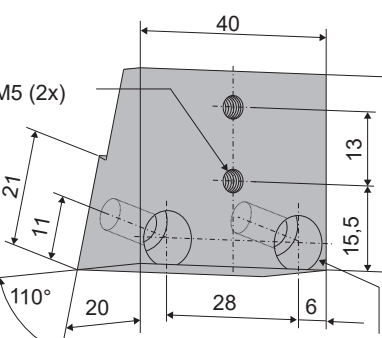
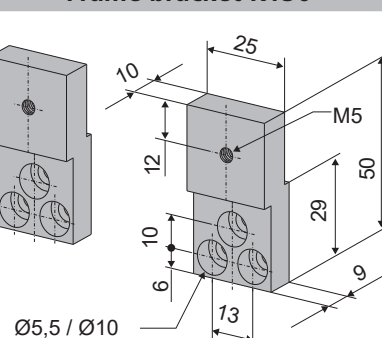
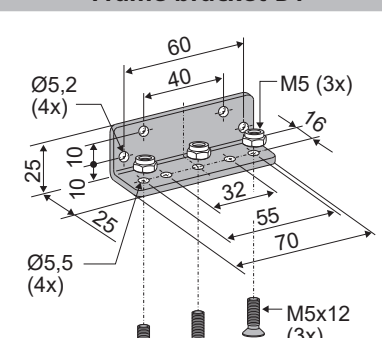
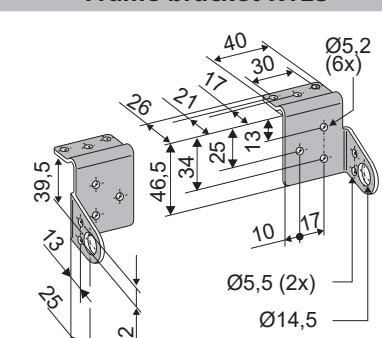
Hole layouts for frame brackets		
<p><b>Frame bracket K105-B</b></p>  <p>use with F17, F18, F19, F20</p>	<p><b>Frame bracket K105-A</b></p>  <p>use with F17</p>	<p><b>Frame bracket K105-A-W77</b></p>  <p>use with F18-1</p>
<p><b>Frame bracket K106</b></p>  <p>use with F19, F20</p>	<p><b>Frame bracket K93</b></p>  <p>use with F41</p>	<p><b>Frame bracket K94</b></p>  <p>use with F35, F37, F41</p>
<p><b>Frame bracket K96-1</b></p>  <p>use with F95</p>	<p><b>Frame bracket K129</b></p>  <p>use with F35, F37, F41</p>	<p><b>Frame bracket K128</b></p>  <p>roof window Schüco AWS 57RO</p>
<p><b>Frame bracket K130</b></p>  <p>friction hinged window Schüco AWS102 SK</p>	<p><b>Frame bracket B1</b></p>  <p>on skylight dome use with F21 and K125</p>	<p><b>Frame bracket K125</b></p>  <p>on skylight dome use with B1 and F21</p>

APPLICATION EXAMPLES

<p><b>Top hung outward opening Window frame assembly</b></p>	<p><b>Bottom hung inward opening Window casement assembly</b></p>	<p><b>Bottom hung inward opening Window casement assembly</b></p>
<p>View on the aluminum window</p>	<p>View on the aluminum window</p>	<p>View on the wood window</p>
<p><b>Top hung outward opening Window frame assembly</b></p>	<p><b>Bottom hung inward opening Window frame assembly</b></p>	<p><b>Bottom hung inward opening Window frame assembly</b></p>
<p>View on the aluminum window</p>	<p>View on the steel window</p>	<p>View on the aluminum window</p>
<p><b>Bottom hung inward opening Window frame assembly</b></p>	<p><b>Bottom hung inward opening Profileinbau</b></p>	<p><b>Top hung outward opening Window frame assembly</b></p>
<p>View on the aluminum window</p>	<p>View in the aluminum profile</p>	<p>View on the aluminum window (Facade)</p>

**INSTALLATION STEP 5A: HOLE LAYOUT FOR K94 / K129 + CASEMENT BRACKET F41**

Solo application KS2 xxx / Version: Right

(Bottom-hung - inward opening)

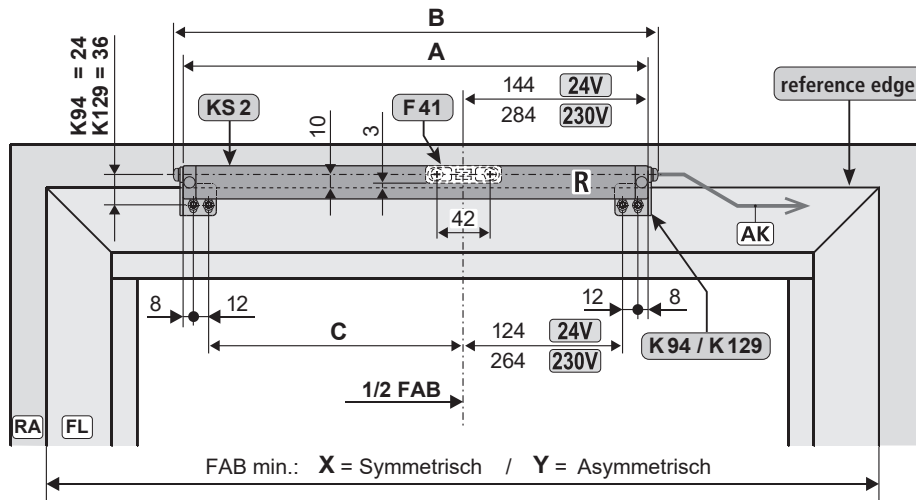

Possible versions	
Bottom-hung	- inward opening
Top-hung	- inward opening
Side-hung	- inward opening
Horizontally pivoting casement	
<b>Version Left (L):</b> as right (R), but in mirror image	
When mounting two drives (tandem operation), a minimum distance of 50 mm between the drives is considered.	

24V					
	Stroke 200	Stroke 300	Stroke 400	Stroke 500 + 600	Stroke 800
<b>A</b>	337	382	432	547	627
<b>B</b>	351	396	446	561	641
<b>C</b>	173	218	268	383	463
<b>X</b>	≥ 385	≥ 475	≥ 575	≥ 805	≥ 965
<b>Y</b>	≥ 335	≥ 380	≥ 430	≥ 545	≥ 625

230V					
	Stroke 200	Stroke 300	Stroke 400	Stroke 500 + 600	Stroke 800
<b>A</b>	477	522	572	687	767
<b>B</b>	491	536	586	701	781
<b>C</b>	173	218	268	383	463
<b>X</b>	≥ 575	≥ 575	≥ 575	≥ 805	≥ 965
<b>Y</b>	≥ 475	≥ 520	≥ 570	≥ 685	≥ 765

Tensile load - Casement assembly - Drive ride-on

(Bottom-hung - inward opening)

Frame bracket: K94  
Casement bracket: F41  
Drive: fix  
Space on the frame: 16 mm

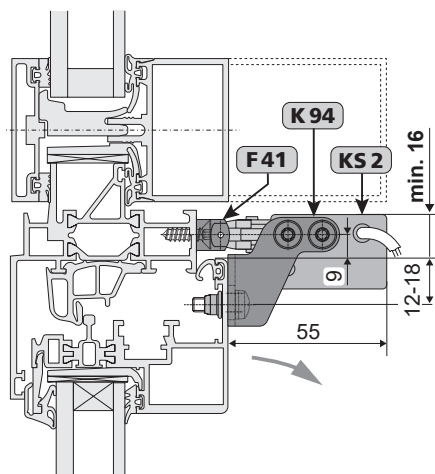

Minimum overall height of casement						
Stroke	200	300	400	500	600	800
Height	325	500	750	975	1200	1600

Frame bracket: K94  
Casement bracket: F41  
Drive: fest  
Space on the frame: 21 mm

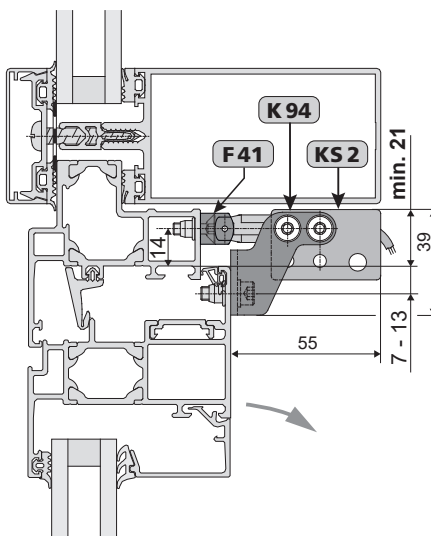

Minimum overall height of casement						
Stroke	200	300	400	500	600	800
Height	325	450	550	675	800	1080

Frame bracket: K129  
Casement bracket: F41  
Drive: fix  
Space on the frame: 25 mm

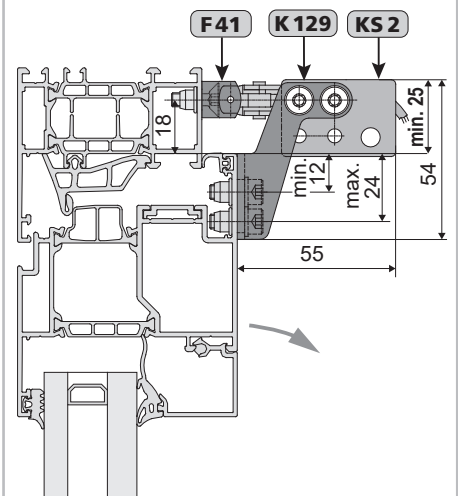

Minimum overall height of casement						
Stroke	200	300	400	500	600	800
Height	325	450	550	675	800	1080

# INSTALLATION STEP 5B: HOLE LAYOUT FOR KS2 DRIVE + CASEMENT BRACKETS F42

Solo application KS2 xxx / Version: Right (Bottom-hung - inward opening)

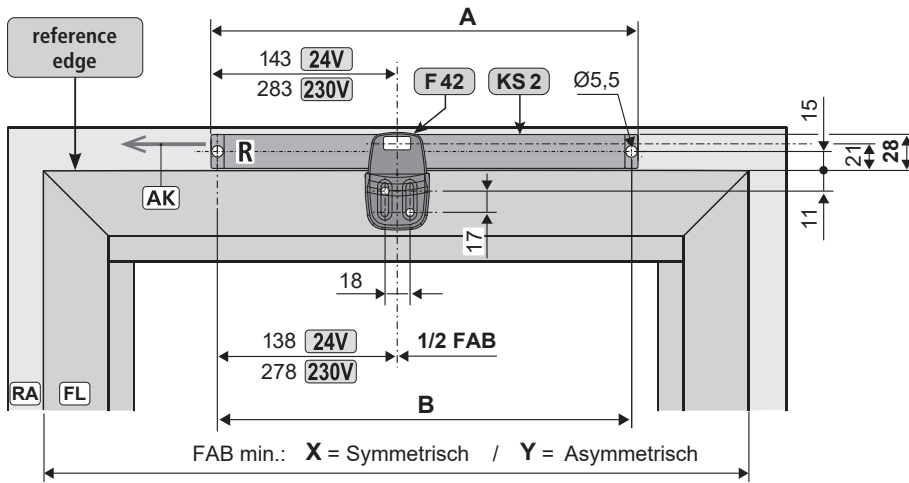

Possible versions	
Bottom-hung	- inward opening
Top-hung	- inward opening
Side-hung	- inward opening
Horizontally pivoting casement	
Version Left (L): as right (R), but in mirror image	
When mounting two drives (tandem operation), a minimum distance of 50 mm between the drives is considered.	

24V					
	Stroke 200	Stroke 300	Stroke 400	Stroke 500 + 600	Stroke 800
<b>A</b>	335	380	430	545	625
<b>B</b>	325	370	420	535	615
<b>X</b>	≥ 385	≥ 475	≥ 575	≥ 805	≥ 965
<b>Y</b>	≥ 335	≥ 380	≥ 430	≥ 545	≥ 625

230V					
	Stroke 200	Stroke 300	Stroke 400	Stroke 500 + 600	Stroke 800
<b>A</b>	475	520	570	685	765
<b>B</b>	465	510	560	675	755
<b>X</b>	≥ 575	≥ 575	≥ 575	≥ 805	≥ 965
<b>Y</b>	≥ 475	≥ 520	≥ 570	≥ 685	≥ 765

Tensile load - Window frame assembly - Drive stationary (Bottom-hung - inward opening)

Frame bracket: -  
Casement bracket: F42  
Drive: fix  
Space on the frame: 28 mm

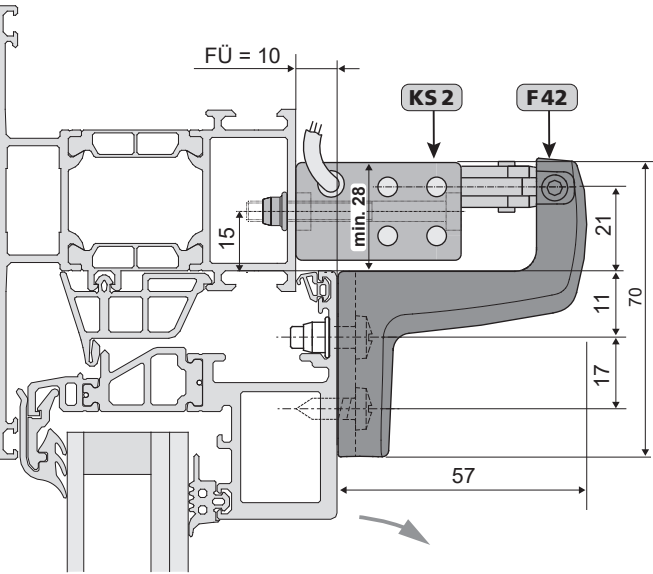

Minimum overall height of casement (FAH)						
Stroke	200	300	400	500	600	800
<b>Height</b>	425	500	600	775	950	1250

Frame bracket: -  
Casement bracket: F95  
Drive: fix  
Space on the frame: 28 mm

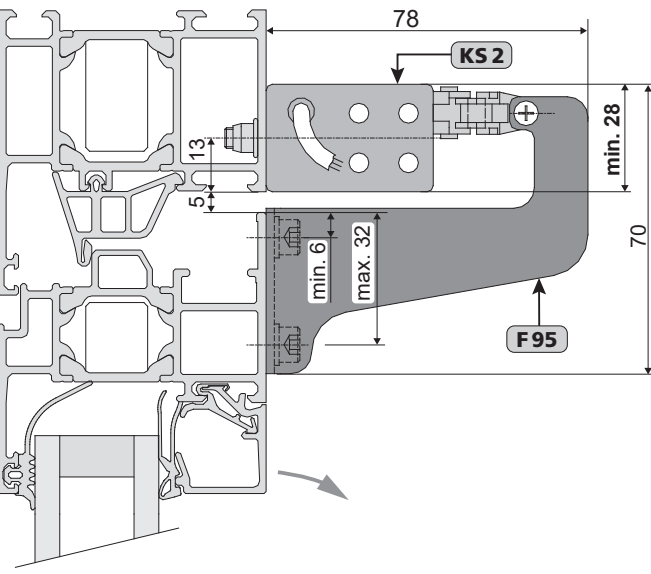

Minimum overall height of casement (FAH)						
Stroke	200	300	400	500	600	800
<b>Height</b>	425	500	600	775	950	1250

05



### INSTALLATION STEP 5c: HOLE LAYOUT FOR K96-1 + CASEMENT BRACKET F95

Solo application KS2 xxx / Version: Right

(Bottom-hung - inward opening)

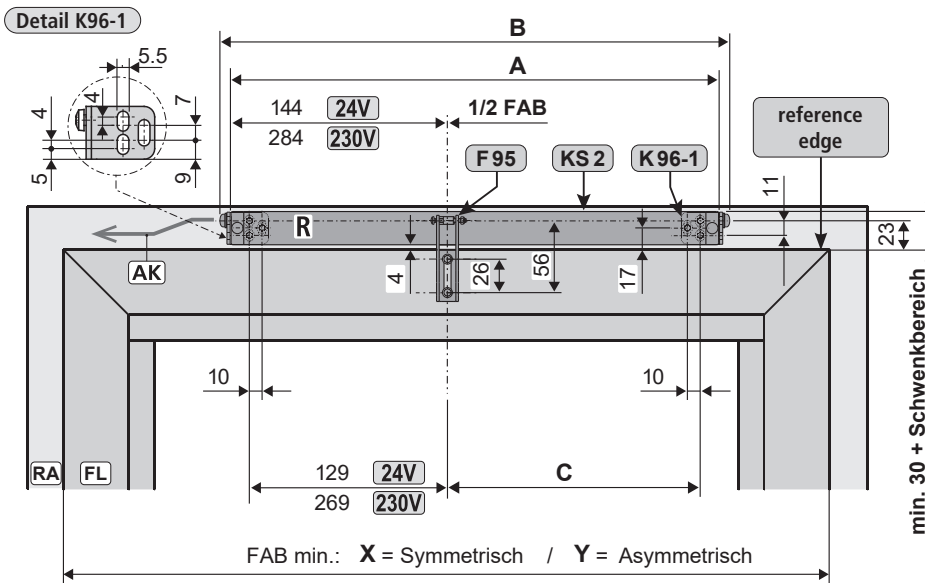

Possible versions	
Bottom-hung	- inward opening
Side-hung	- inward opening
Horizontally pivoting casement	
Version Left (L): as right (R), but in mirror image	
When mounting two drives (tandem operation), a minimum distance of 50 mm between the drives is considered.	

24V					
	Stroke 200	Stroke 300	Stroke 400	Stroke 500 + 600	Stroke 800
<b>A</b>	337	382	432	547	627
<b>B</b>	351	396	446	561	641
<b>C</b>	178	223	273	388	468
<b>X</b>	≥ 385	≥ 475	≥ 575	≥ 805	≥ 965
<b>Y</b>	≥ 335	≥ 380	≥ 430	≥ 545	≥ 625

230V					
	Stroke 200	Stroke 300	Stroke 400	Stroke 500 + 600	Stroke 800
<b>A</b>	477	522	572	687	767
<b>B</b>	491	536	586	701	781
<b>C</b>	178	223	273	388	468
<b>X</b>	≥ 575	≥ 575	≥ 575	≥ 805	≥ 965
<b>Y</b>	≥ 475	≥ 520	≥ 570	≥ 685	≥ 765

Tensile load - Window frame assembly - Drive stationary

(Bottom-hung - inward opening)

Frame bracket: K96-1  
 Casement bracket: F95  
 Drive: swiveling

Space on the frame: 30 mm

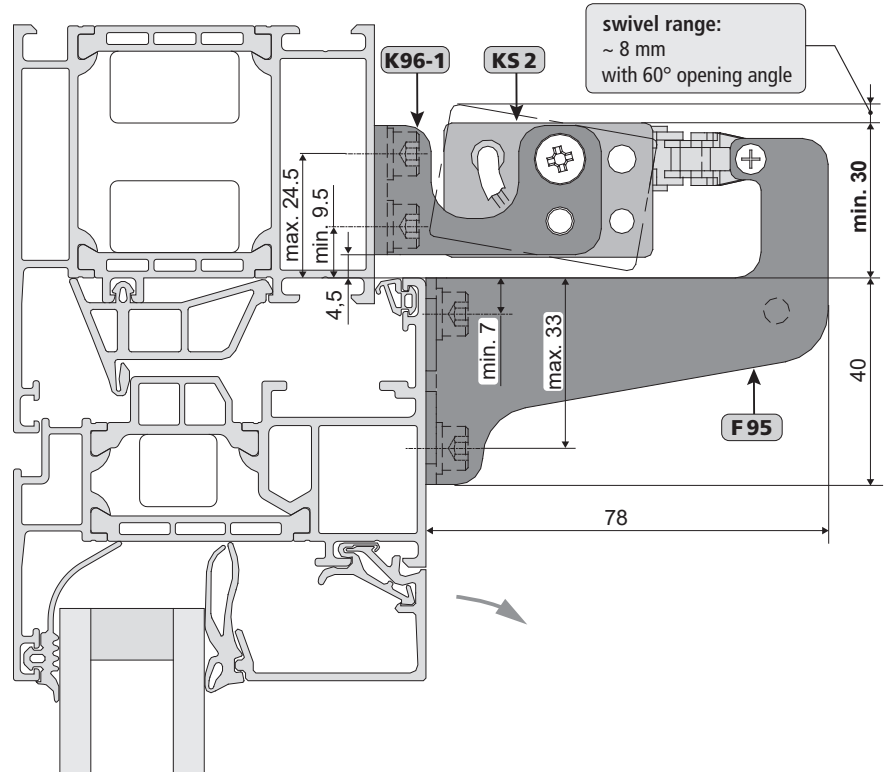

Minimum overall height of casement						
Stroke	200	300	400	500	600	800
Height	250	325	400	500	600	800

# INSTALLATION STEP 5D: HOLE LAYOUT FOR FRAME BRACKET K94 + CASEMENT BRACKET F41

Solo application KS2 xxx / Version: Right (Bottom-hung - outward opening)

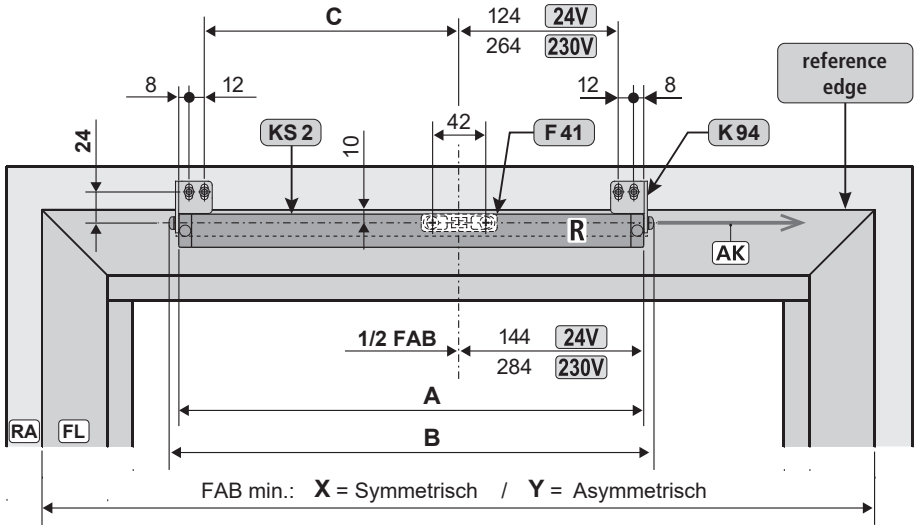

Possible versions	
Bottom-hung	- outward opening
Top-hung	- outward opening
Side-hung	- outward opening
Horizontally pivoting casement	
Projecting top-hung casement	
Version Left (L): as right (R), but in mirror image	
When mounting two drives (tandem operation), a minimum distance of 50 mm between the drives is considered.	

24V					
	Stroke 200	Stroke 300	Stroke 400	Stroke 500 + 600	Stroke 800
<b>A</b>	337	382	432	547	627
<b>B</b>	351	396	446	561	641
<b>C</b>	173	218	268	383	463
<b>X</b>	≥ 385	≥ 475	≥ 575	≥ 805	≥ 965
<b>Y</b>	≥ 335	≥ 380	≥ 430	≥ 545	≥ 625

230V					
	Stroke 200	Stroke 300	Stroke 400	Stroke 500 + 600	Stroke 800
<b>A</b>	477	522	572	687	767
<b>B</b>	491	536	586	701	781
<b>C</b>	173	218	268	383	463
<b>X</b>	≥ 575	≥ 575	≥ 575	≥ 805	≥ 965
<b>Y</b>	≥ 475	≥ 520	≥ 570	≥ 685	≥ 765

## Tensile load - Window frame assembly - Drive stationary (Bottom-hung - outward opening)

Frame bracket: K94  
 Casement bracket: F41  
 Drive: fix  
 Space on the frame: 22 mm

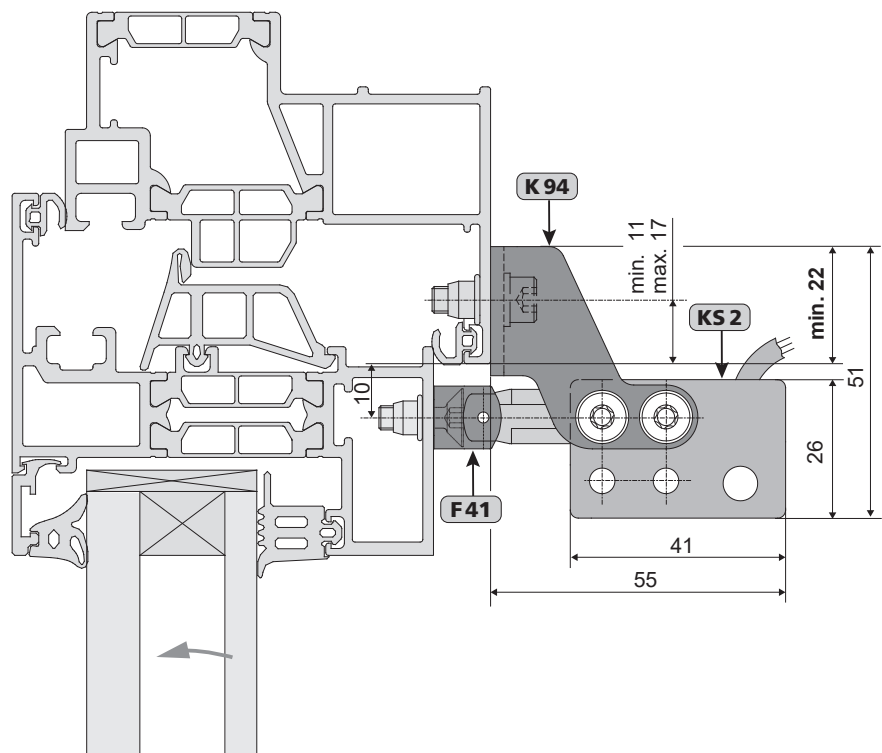

Minimum overall height of casement						
Stroke	200	300	400	500	600	800
Height	325	450	550	675	800	1080

05



### INSTALLATION STEP 5E: HOLE LAYOUT FOR K130 + CASEMENT BRACKET F21

Solo application KS2 xxx / Version: Right

(Top-hung - outward opening)

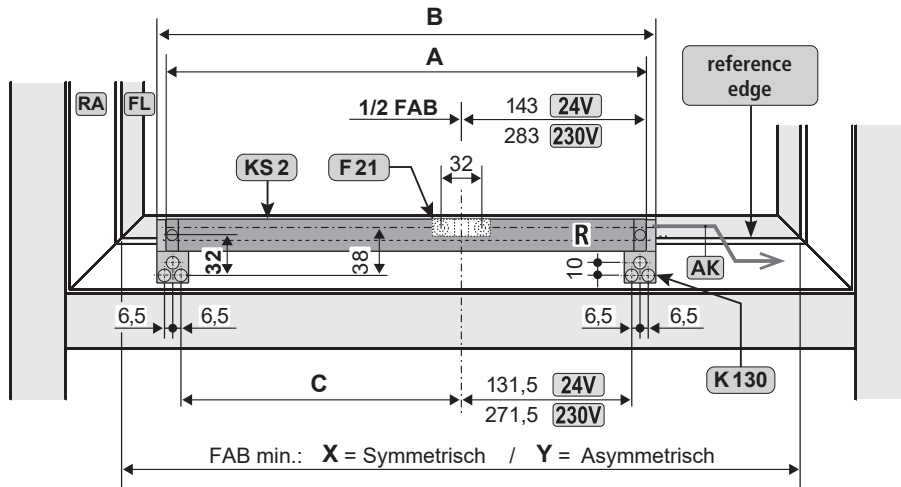

Possible versions	
Top-hung - outward opening	
Roof top-hung	
Projecting top-hung casement	
<b>Version Left (L):</b> as right (R), but in mirror image	
When mounting two drives (tandem operation), a minimum distance of 50 mm between the drives is considered.	

24V				
	Stroke 200	Stroke 300	Stroke 400	Stroke 500
<b>A</b>	335	380	430	545
<b>B</b>	350	395	445	560
<b>C</b>	180,5	225,5	275,5	390,5
<b>X</b>	≥ 400	≥ 490	≥ 590	≥ 820
<b>Y</b>	≥ 350	≥ 395	≥ 445	≥ 560

230V				
	Stroke 200	Stroke 300	Stroke 400	Stroke 500
<b>A</b>	475	520	570	685
<b>B</b>	490	535	585	700
<b>C</b>	180,5	225,5	275,5	390,5
<b>X</b>	≥ 590	≥ 590	≥ 590	≥ 820
<b>Y</b>	≥ 490	≥ 535	≥ 585	≥ 700

Pressure load - Window frame assembly - Drive stationary

(Top-hung - outward opening)

Frame bracket: K130  
 Casement bracket: F21  
 Drive: fix

Space on the frame: 22 mm

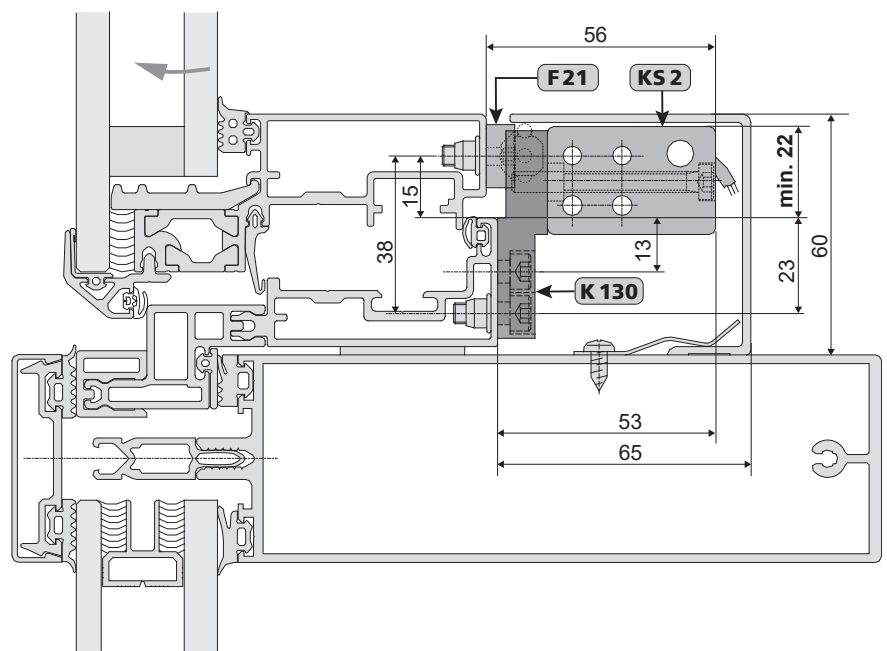

Minimum overall height of casement				
Stroke	200	300	400	500
<b>Height</b>	350	400	450	600

**INSTALLATION STEP 5F: HOLE LAYOUT FOR FRAME BRACKET K94 + CASEMENT BRACKET F41**

Solo application KS2 xxx / Version: Right (Top-hung - outward opening)

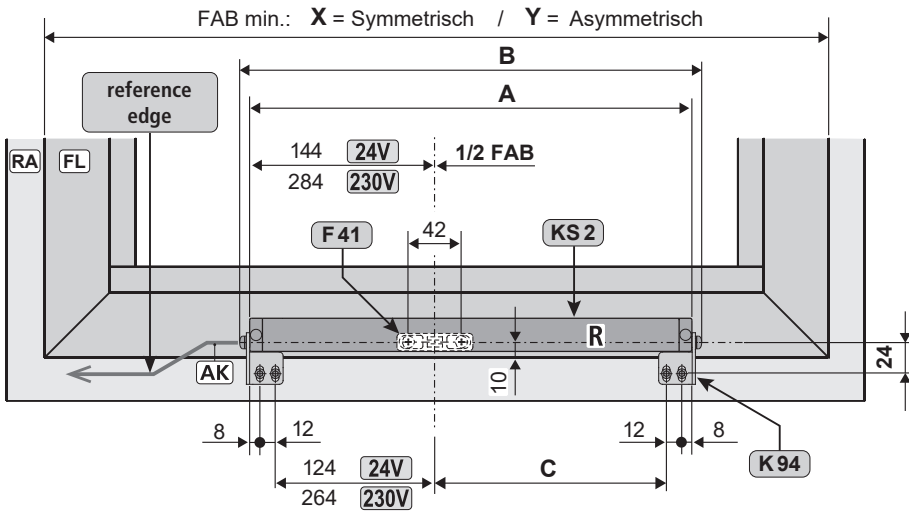

Possible versions	
Bottom-hung	- outward opening
Top-hung	- outward opening
Side-hung	- outward opening
Horizontally pivoting casement	
Projecting top-hung casement	
Version Left (L): as right (R), but in mirror image	
When mounting two drives (tandem operation), a minimum distance of 50 mm between the drives is considered.	

24V				
	Stroke 200	Stroke 300	Stroke 400	Stroke 500
<b>A</b>	337	382	432	547
<b>B</b>	351	396	446	561
<b>C</b>	173	218	268	383
<b>X</b>	≥ 385	≥ 475	≥ 575	≥ 805
<b>Y</b>	≥ 335	≥ 380	≥ 430	≥ 545

230V				
	Stroke 200	Stroke 300	Stroke 400	Stroke 500
<b>A</b>	477	522	572	687
<b>B</b>	491	536	586	701
<b>C</b>	173	218	268	383
<b>X</b>	≥ 575	≥ 575	≥ 575	≥ 805
<b>Y</b>	≥ 475	≥ 520	≥ 570	≥ 685

Pressure load - Window frame assembly - Drive stationary (Top-hung - outward opening)

Frame bracket: K94  
 Casement bracket: F41  
 Drive: fix

Space on the frame: 22 mm

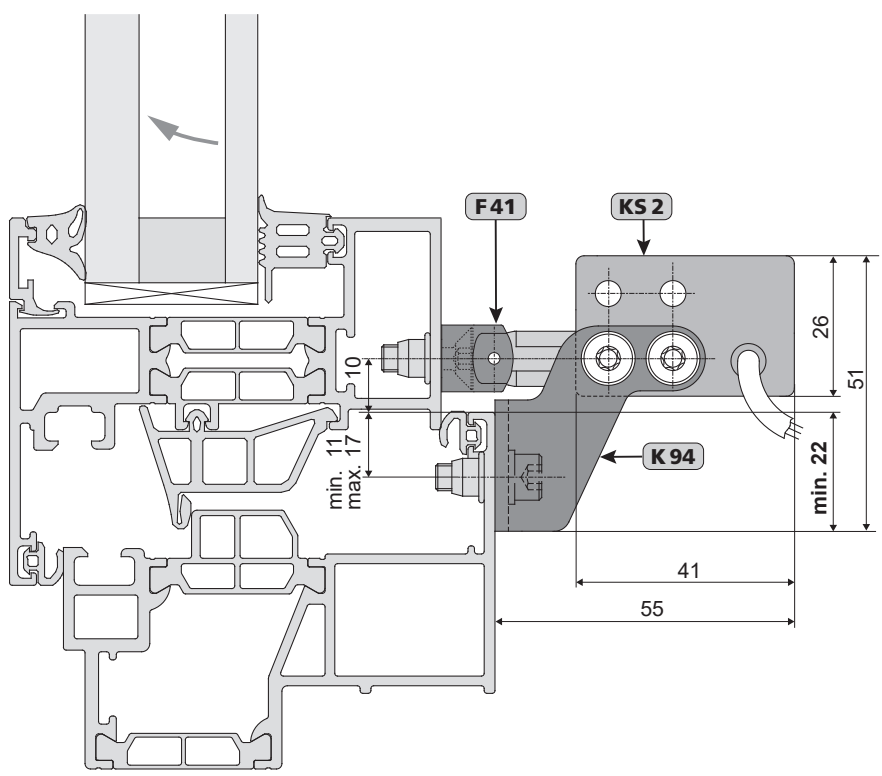

Minimum overall height of casement				
Stroke	200	300	400	500
<b>Height</b>	350	400	450	600

05

### INSTALLATION STEP 5G: HOLE LAYOUT FOR FRAME BRACKET K94 + CASEMENT BRACKET F41

Solo application KS2 xxx / Version: Right

(Top-hung - outward opening)

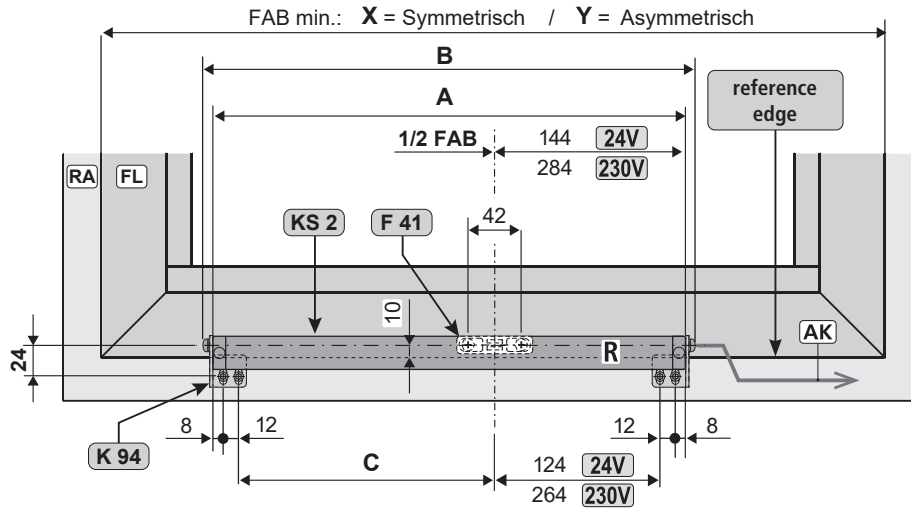

Possible versions	
Bottom-hung	- outward opening
Top-hung	- outward opening
Side-hung	- outward opening
Horizontally pivoting casement	
Projecting top-hung casement	
Version Left (L): as right (R), but in mirror image	
When mounting two drives (tandem operation), a minimum distance of 50 mm between the drives is considered.	

24V				
	Stroke 200	Stroke 300	Stroke 400	Stroke 500
<b>A</b>	337	382	432	547
<b>B</b>	351	396	446	561
<b>C</b>	173	218	268	383
<b>X</b>	≥ 385	≥ 475	≥ 575	≥ 805
<b>Y</b>	≥ 335	≥ 380	≥ 430	≥ 545

230V				
	Stroke 200	Stroke 300	Stroke 400	Stroke 500
<b>A</b>	477	522	572	687
<b>B</b>	491	536	586	701
<b>C</b>	173	218	268	383
<b>X</b>	≥ 575	≥ 575	≥ 575	≥ 805
<b>Y</b>	≥ 475	≥ 520	≥ 570	≥ 685

Pressure load - Window frame assembly - Drive stationary

(Top-hung - outward opening)

Frame bracket: K94  
 Casement bracket: F41  
 Drive: fix, turned

Space on the frame: 22 mm

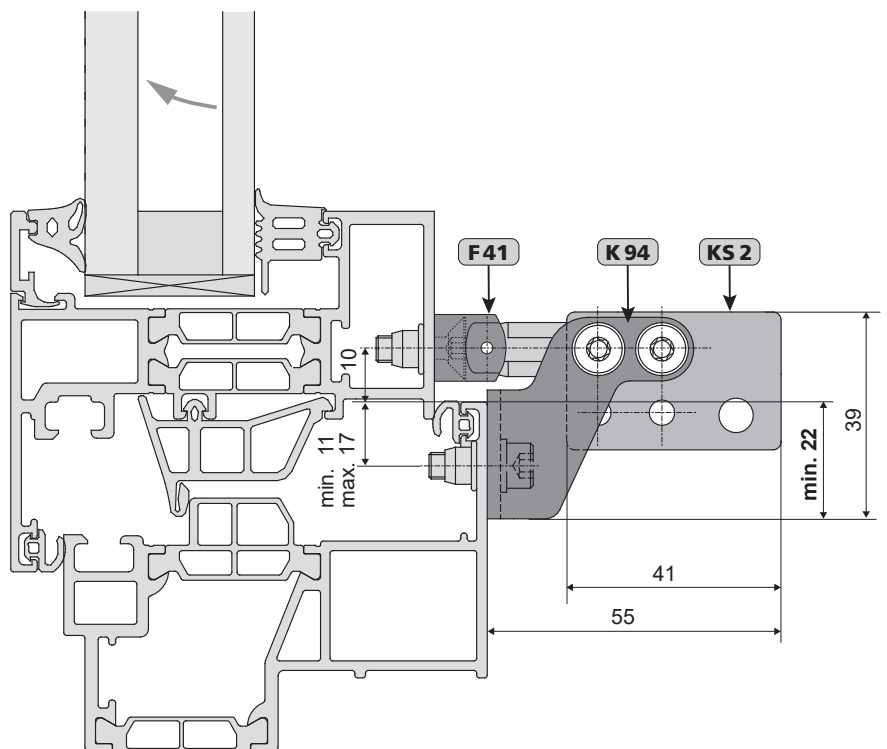

Minimum overall height of casement				
Stroke	200	300	400	500
Height	400	500	700	800

# INSTALLATION STEP 5H: HOLE LAYOUT FOR K128 + CASEMENT BRACKET F21

Solo application KS2 xxx / Version: Right (Top-hung - outward opening)

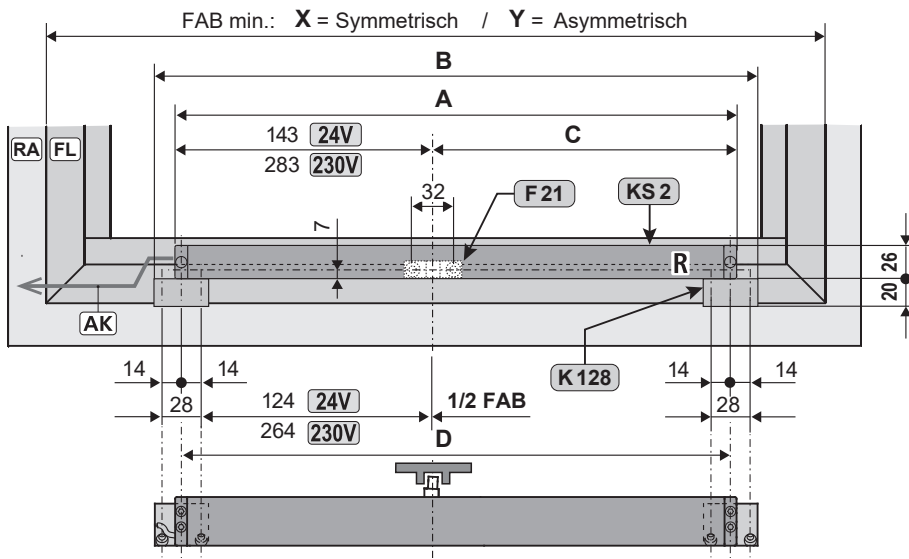

Possible versions	
Bottom-hung	- outward opening
Top-hung	- outward opening
Side-hung	- outward opening
Version Left (L): as right (R), but in mirror image	
When mounting two drives (tandem operation), a minimum distance of 50 mm between the drives is considered.	

24V				
	Stroke 200	Stroke 300	Stroke 400	Stroke 500
<b>A</b>	335	380	430	545
<b>B</b>	365	410	460	575
<b>C</b>	192	237	287	402
<b>D</b>	325	370	420	535
<b>X</b>	≥ 415	≥ 505	≥ 605	≥ 835
<b>Y</b>	≥ 365	≥ 410	≥ 460	≥ 575

230V				
	Stroke 200	Stroke 300	Stroke 400	Stroke 500
<b>A</b>	475	520	570	685
<b>B</b>	505	550	600	715
<b>C</b>	192	237	287	402
<b>D</b>	465	510	560	675
<b>X</b>	≥ 605	≥ 605	≥ 605	≥ 835
<b>Y</b>	≥ 505	≥ 550	≥ 600	≥ 715

Pressure load - Window frame assembly - Drive stationary (Top-hung - outward opening)

Frame bracket: K128  
 Casement bracket: F21  
 Drive: fix  
 Assembly on Schüco AWS 57RO

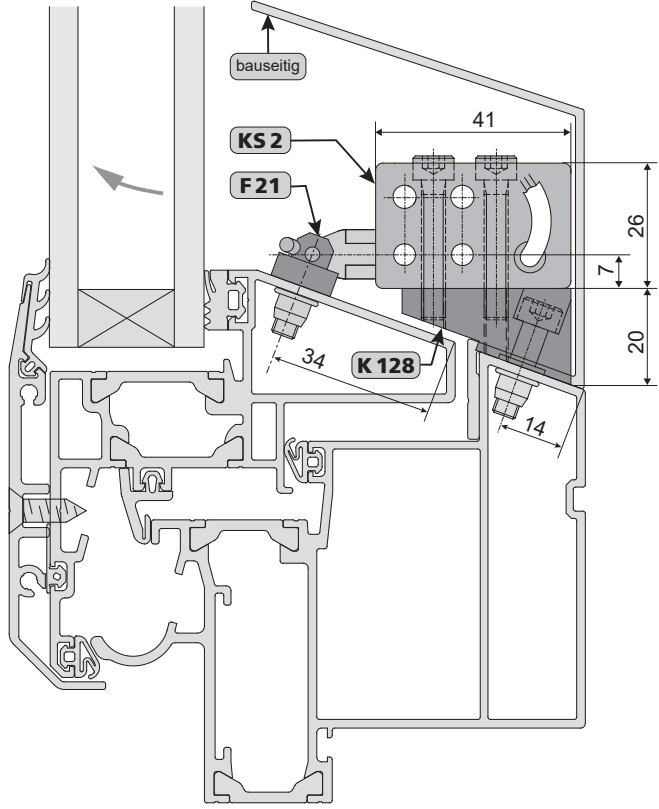
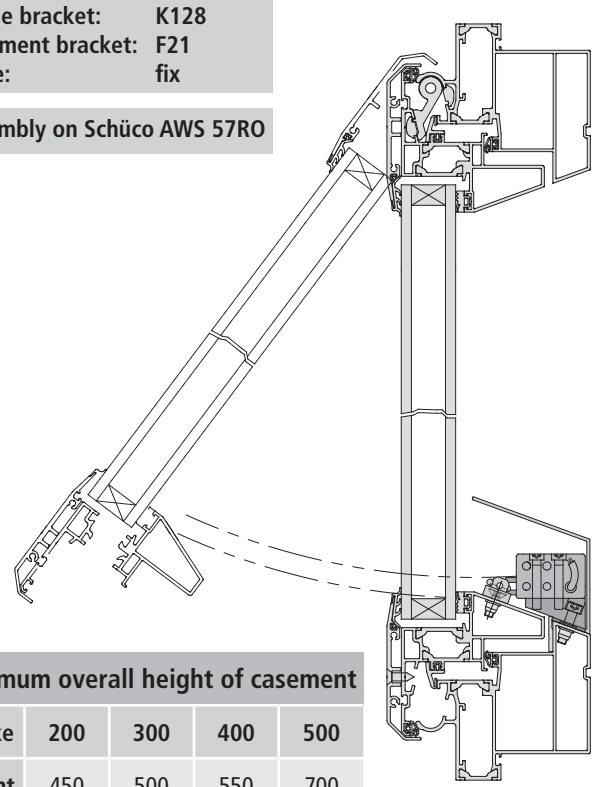

Minimum overall height of casement				
Stroke	200	300	400	500
Height	450	500	550	700

05

### INSTALLATION STEP 5i: HOLE LAYOUT FOR KS2 DRIVE + CASEMENT BRACKETS F42

Solo application KS2 xxx / Version: Right

(Top-hung - inward opening)

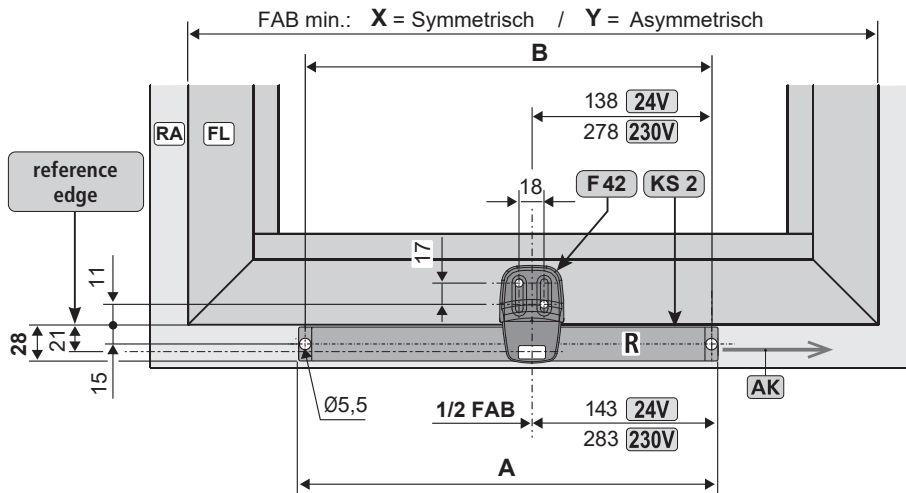

Possible versions	
Bottom-hung	- inward opening
Top-hung	- inward opening
Side-hung	- inward opening
Horizontally pivoting casement	
Version Left (L): as right (R), but in mirror image	
When mounting two drives (tandem operation), a minimum distance of 50 mm between the drives is considered.	

24V				
	Stroke 200	Stroke 300	Stroke 400	Stroke 500 + 600
<b>A</b>	335	380	430	545
<b>B</b>	325	370	420	535
<b>X</b>	≥ 380	≥ 470	≥ 570	≥ 800
<b>Y</b>	≥ 335	≥ 380	≥ 430	≥ 545

230V				
	Stroke 200	Stroke 300	Stroke 400	Stroke 500 + 600
<b>A</b>	475	520	570	685
<b>B</b>	465	510	560	675
<b>X</b>	≥ 570	≥ 570	≥ 570	≥ 800
<b>Y</b>	≥ 475	≥ 520	≥ 570	≥ 685

Pressure load - Window frame assembly - Drive stationary

(Top-hung - inward opening)

Frame bracket: -  
Casement bracket: F42  
Drive: fix

Space on the frame: 28 mm

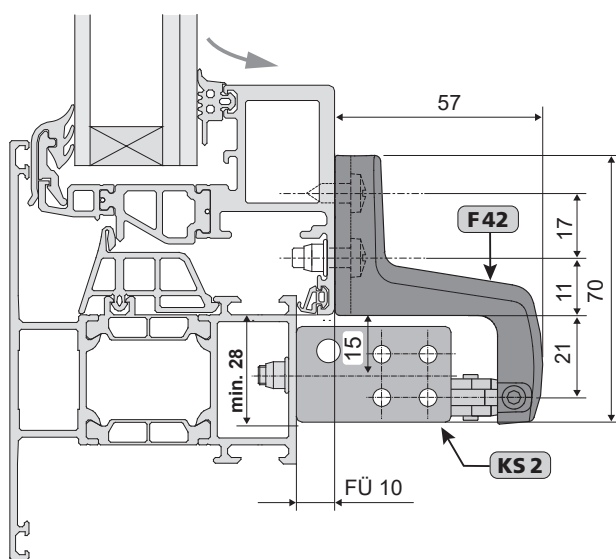

Minimum overall height of casement (FAH)				
Stroke	200	300	400	500
Height	350	400	450	700

Frame bracket: -  
Casement bracket: F95  
Drive: fix

Space on the frame: 28 mm

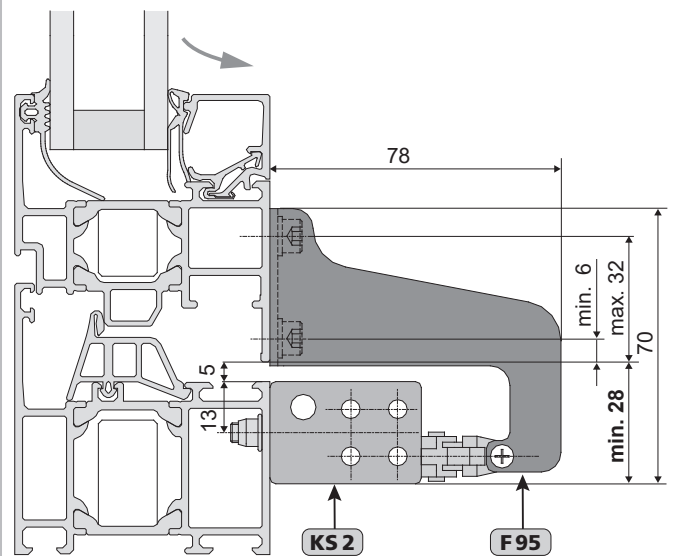

Minimum overall height of casement (FAH)				
Stroke	200	300	400	500
Height	350	400	450	700

**INSTALLATION STEP 5j: HOLE LAYOUT FOR FRAME BRACKET K94 + CASEMENT BRACKET F41**

Solo application KS2 xxx / Version: Right (Top-hung - inward opening)

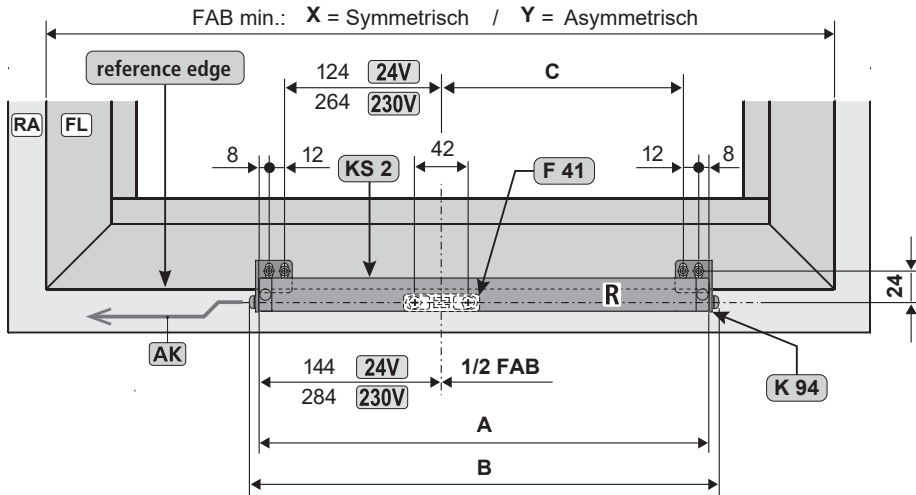

Possible versions	
Bottom-hung	- inward opening
Top-hung	- inward opening
Side-hung	- inward opening
Version Left (L): as right (R), but in mirror image	
When mounting two drives (tandem operation), a minimum distance of 50 mm between the drives is considered.	

24V				
	Stroke 200	Stroke 300	Stroke 400	Stroke 500
<b>A</b>	337	382	432	547
<b>B</b>	351	396	446	561
<b>C</b>	173	218	268	383
<b>X</b>	≥ 385	≥ 475	≥ 575	≥ 805
<b>Y</b>	≥ 335	≥ 380	≥ 430	≥ 545

230V				
	Stroke 200	Stroke 300	Stroke 400	Stroke 500
<b>A</b>	477	522	572	687
<b>B</b>	491	536	586	701
<b>C</b>	173	218	268	383
<b>X</b>	≥ 575	≥ 575	≥ 575	≥ 805
<b>Y</b>	≥ 475	≥ 520	≥ 570	≥ 685

Pressure load - Casement assembly - Drive ride-on (Top-hung - inward opening)

Frame bracket: K94  
 Casement bracket: F41  
 Drive: fix

Space on the frame: 16 mm

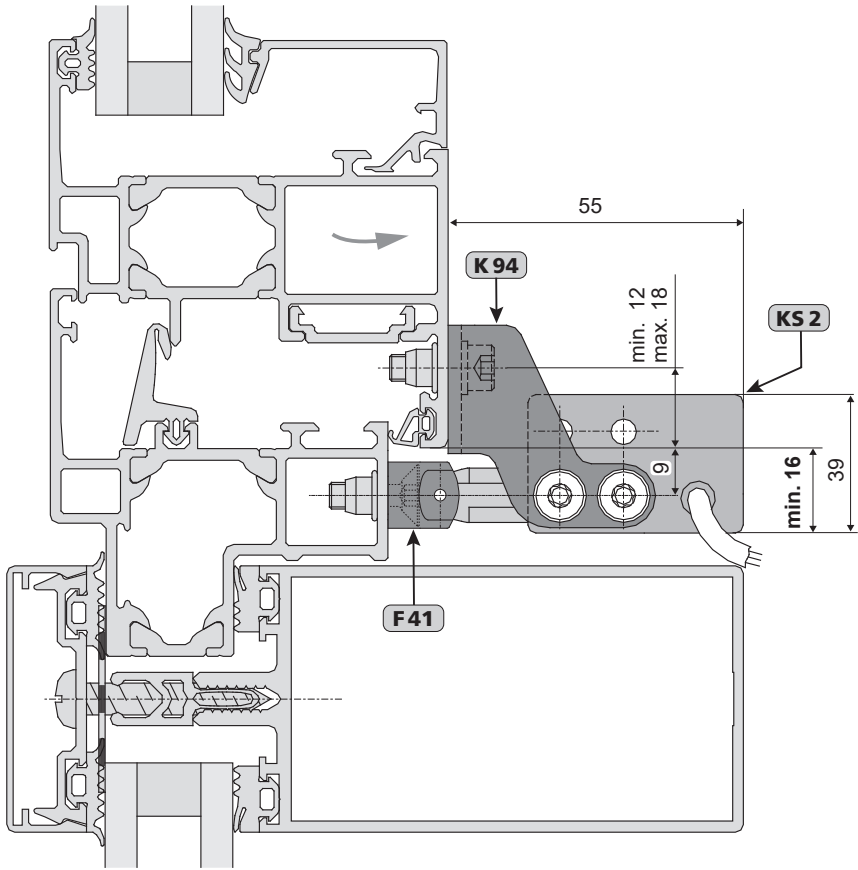

Minimum overall height of casement				
Stroke	200	300	400	500
<b>Height</b>	350	400	450	600

05

# INSTALLATION STEP 5K: HOLE LAYOUT FOR FRAME BRACKET K93 + CASEMENT BRACKET F41

Solo application KS2 xxx / Version: Right

(Top-hung - outward opening)

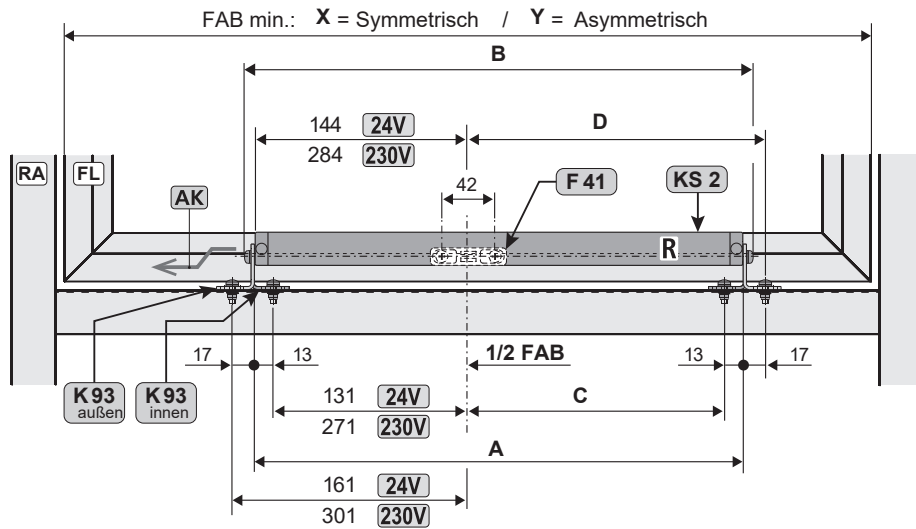

Possible versions	
Bottom-hung	- outward opening
Top-hung	- outward opening
Projecting top-hung casement	
Skylight dome	
Roof bottom-hung	
Roof top-hung	
<b>Version Left (L):</b> as right (R), but in mirror image	
When mounting two drives (tandem operation), a minimum distance of 50 mm between the drives is considered.	

24V				
	Stroke 200	Stroke 300	Stroke 400	Stroke 500
<b>A</b>	337	382	432	547
<b>B</b>	351	396	446	561
Frame bracket K93 inward				
<b>C</b>	180	225	275	390
<b>X</b>	≥ 385	≥ 475	≥ 575	≥ 805
<b>Y</b>	≥ 335	≥ 380	≥ 430	≥ 545
Frame bracket K93 outward				
<b>D</b>	210	255	305	420
<b>X</b>	≥ 445	≥ 535	≥ 635	≥ 865
<b>Y</b>	≥ 395	≥ 440	≥ 490	≥ 605

230V				
	Stroke 200	Stroke 300	Stroke 400	Stroke 500
<b>A</b>	477	522	572	687
<b>B</b>	491	536	586	701
Frame bracket K93 inward				
<b>C</b>	180	225	275	390
<b>X</b>	≥ 575	≥ 575	≥ 575	≥ 805
<b>Y</b>	≥ 475	≥ 520	≥ 570	≥ 685
Frame bracket K93 outward				
<b>D</b>	210	255	305	420
<b>X</b>	≥ 635	≥ 635	≥ 635	≥ 865
<b>Y</b>	≥ 535	≥ 580	≥ 630	≥ 745

Pressure load - Transom assembly - Drive stationary

(Top-hung - outward opening)

Frame bracket: K93  
Casement bracket: F41  
Drive: fix

Space for frame bracket with drive: 30 mm

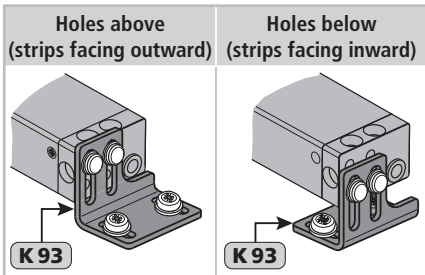

Minimum overall height of casement (FAH)				
Stroke	200	300	400	500
Height	350	400	450	600

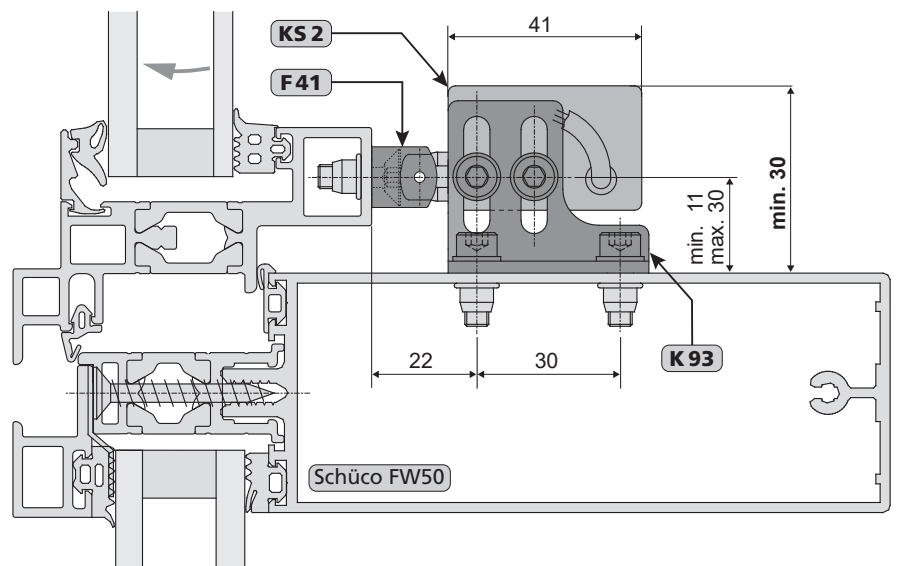

**INSTALLATION STEP 5L:** HOLE LAYOUT FOR K94 / K129 + CASEMENT BRACKET F41 (SIDE DRIVE)

**NSK 24V**

**24V** Tandem application KS2 xxx / Combination Right / Left (Bottom hung - inward opening)

Stroke	Window details				Max. opening
	A	B	C	X	
200	337	351	173	≥ 385	60°
300	382	396	218	≥ 475	60°
400	432	446	268	≥ 575	60°
500	547	561	383	≥ 805	60°
600	547	561	383	≥ 805	60°
800	627	641	463	≥ 965	60°



From FAB > 1200 mm is a locking drive required!



- only for bottom-hung casements (inward opening windows)
- respect max. pulling forces of drives.
- cable exit (power supply) on top.
- rigid-backed side of chain upward.
- white wires must be connected.

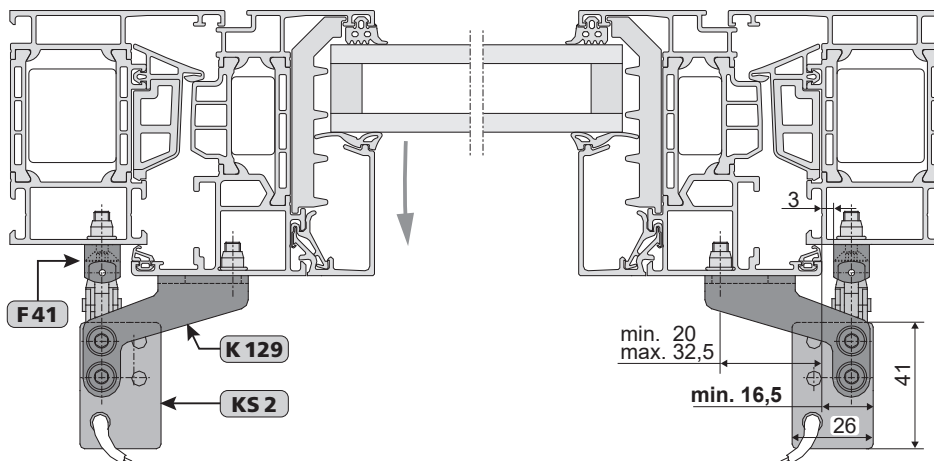
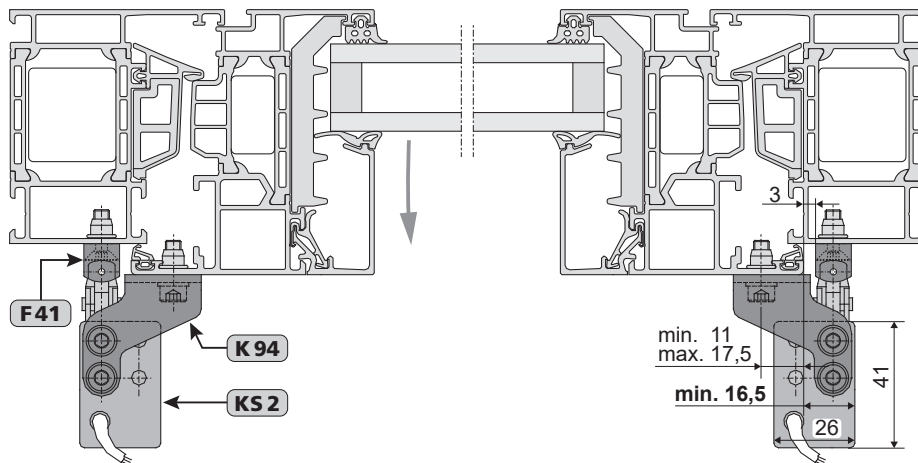
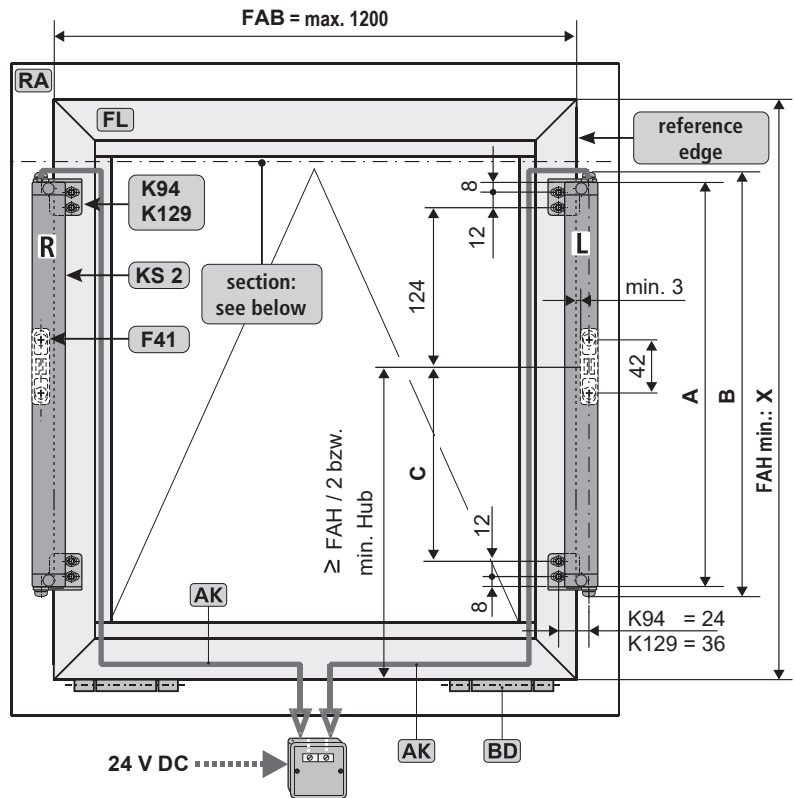



**INSTALLATION STEP 5M:** HOLE LAYOUT FOR CASEMENT BRACKET F42 (SIDE DRIVE)

**NSK 24V**

**24V** Tandem application KS2 xxx / Combination Right / Left (Bottom hung - inward opening)

Stroke	Window details			Max. opening
	A	B	X	
200	335	325	≥ 385	45°
300	380	370	≥ 475	50°
400	430	420	≥ 575	60°
500	545	535	≥ 805	60°
600	545	535	≥ 805	60°
800	625	615	≥ 965	60°

**!** From FAB > 1200 mm is a locking drive required!

- only for bottom-hung casements (inward opening windows)
- respect max. pulling forces of drives.
- cable exit (power supply) on top.
- rigid-backed side of chain upward.
- white wires must be connected.

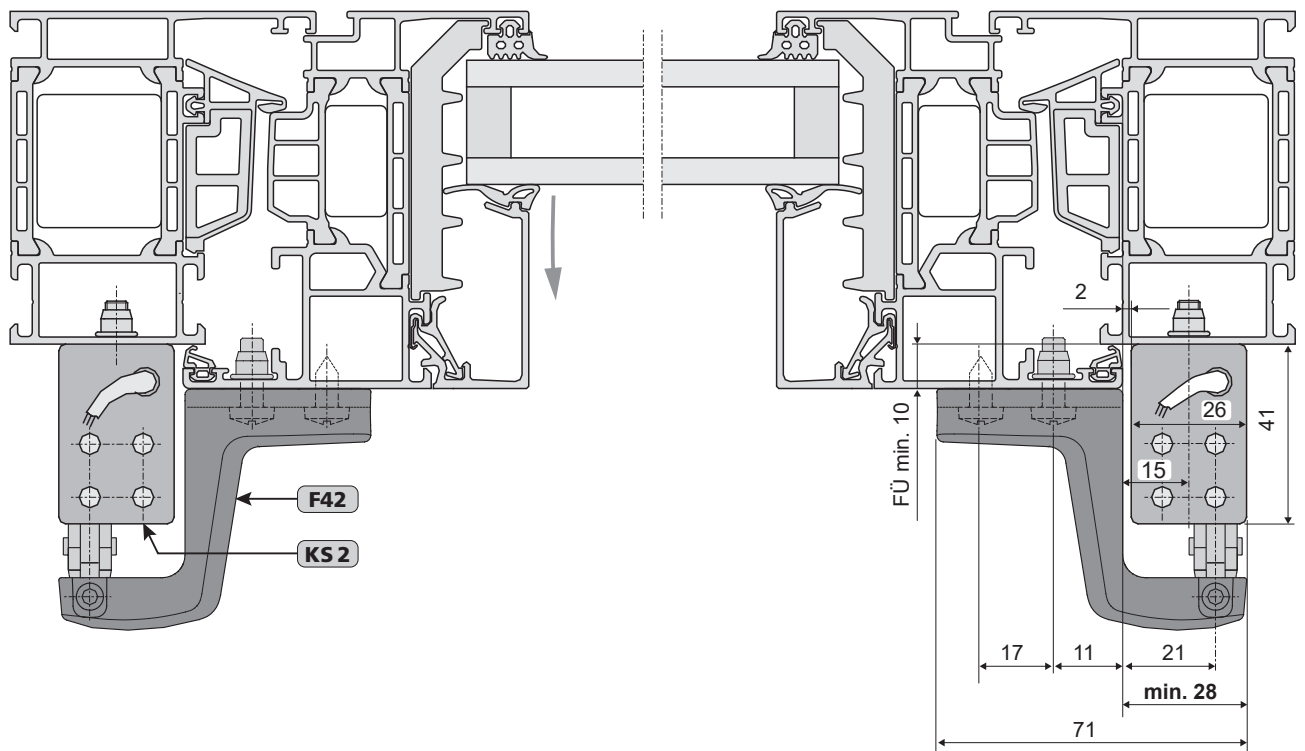
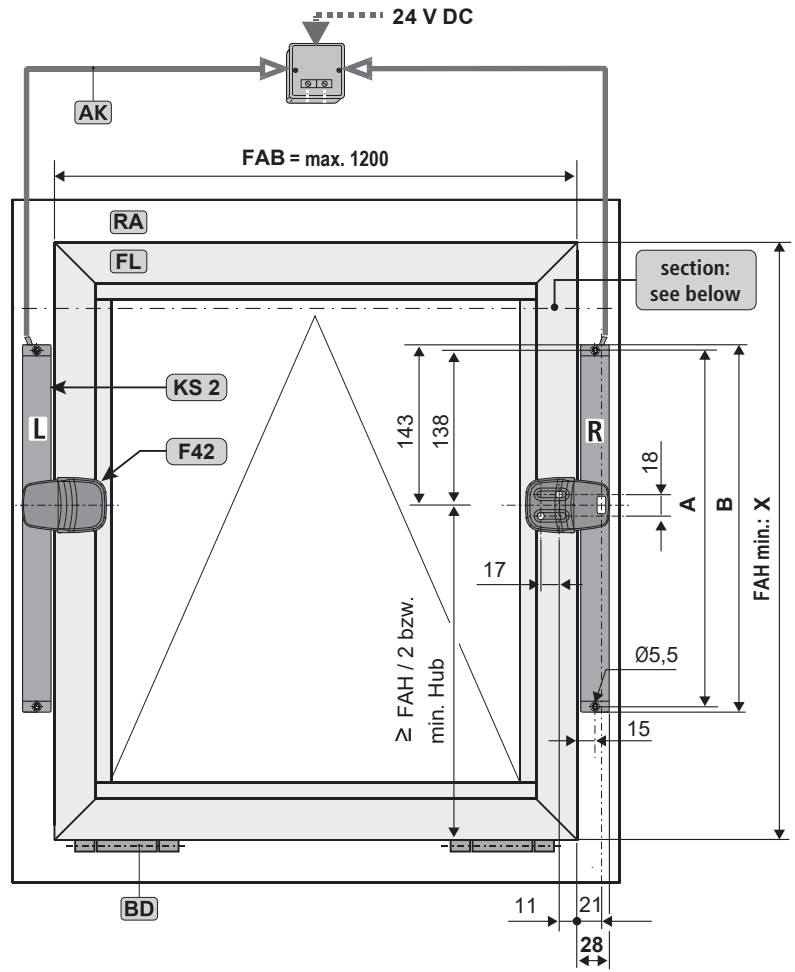

05

**INSTALLATION STEP 6A:** RIGID DRIVE MOUNTING ON THE WINDOW CASEMENT  
 - main closing edge or auxiliary closing edge  
 - inward opening windows



- Determine fastenings.
- Produce drill holes with appropriate cross-section. For the mounting dimensions refer to the hole layout drawings „INSTALLATION STEPE 3 - 5” or project-specific documents and drawings).

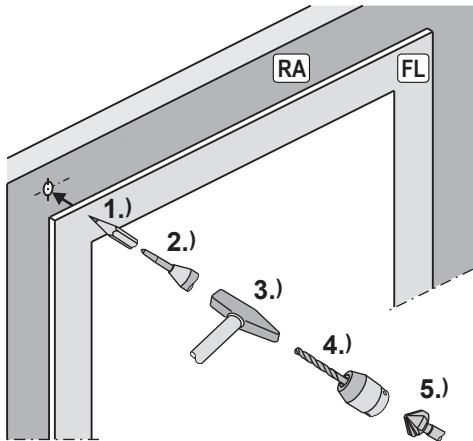

Carefully clear away drilling swarfs to prevent seals from being damaged. Avoid surface scratches, for example by using masking tape.

- Secure fasteners against loosening; e.g. by applying removable thread-locking compound such as "Loctite".

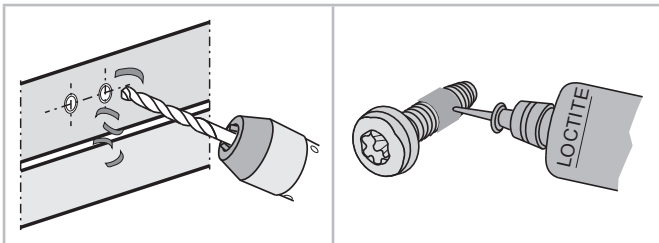

**NOTE** Screws - for mounting on the window - are to be provided by the customer!

- Mount the casement bracket **F41** ① - with on-site screws (M5) - on the frame.



Make sure it is parallel to casement edge. „Casement bracket” center and „chain output” must be in line.

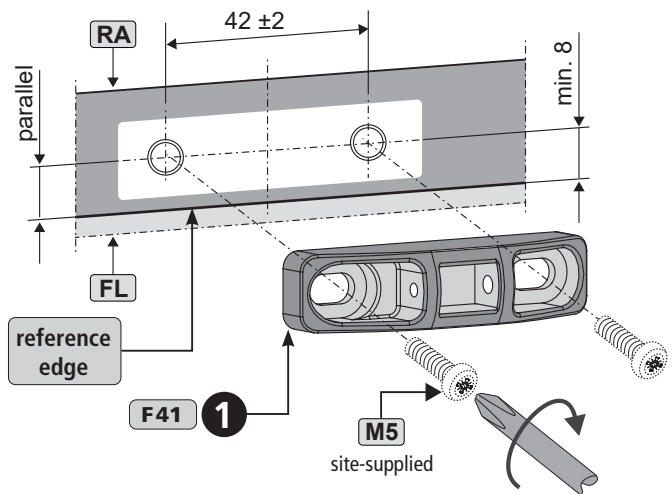
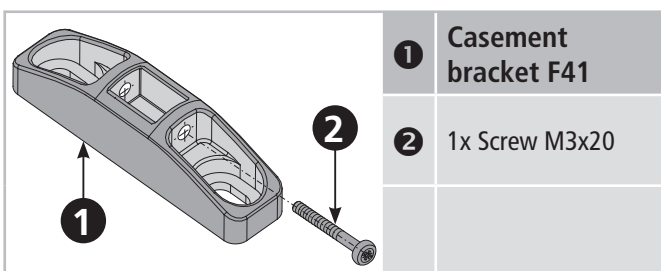

- Mount the frame brackets **K94** ③ - with on-site screws (M5) - on the window casement.



Make sure they are parallel to casement edge.

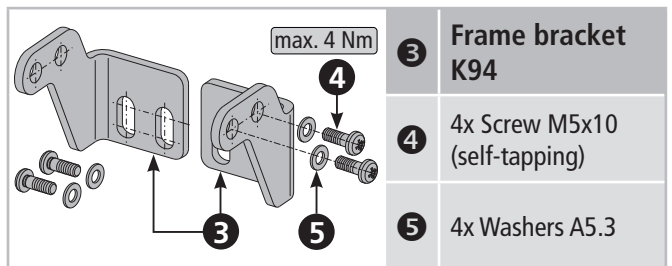

**NOTE** If necessary, use washers. These are depending on the type of screws used.

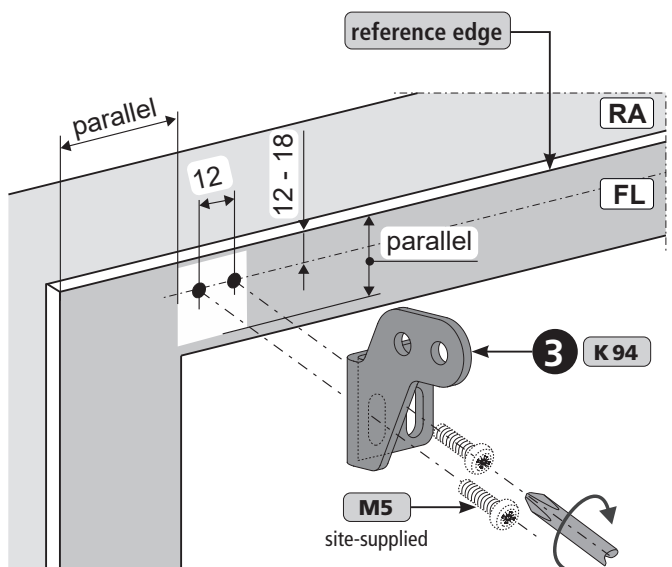

- Attach the KS 2 drive ⑥ in the frame brackets K94 ③.
- Secure the KS 2 drive ⑥ with self-tapping screws M5 ④ and washers ⑤ (max. 4 Nm).

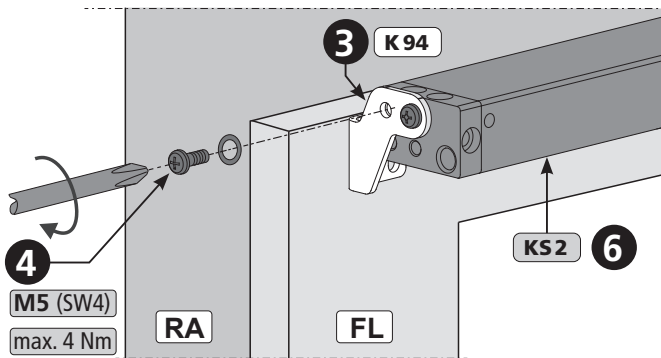

- Apply the control voltage of the KS 2 drive ⑥ (e.g. using a tester).
- Move out the chain of KS 2 drive ⑥ ~ 100 bis 150 mm.

**NOTE**

For multi-drive operation actuate all KS 2 drives **together**.  
(see chapter: ELECTRIC CONNECTION)

- Secure the chain of KS 2 drive - with screw ② - in the casement bracket F41 ①.

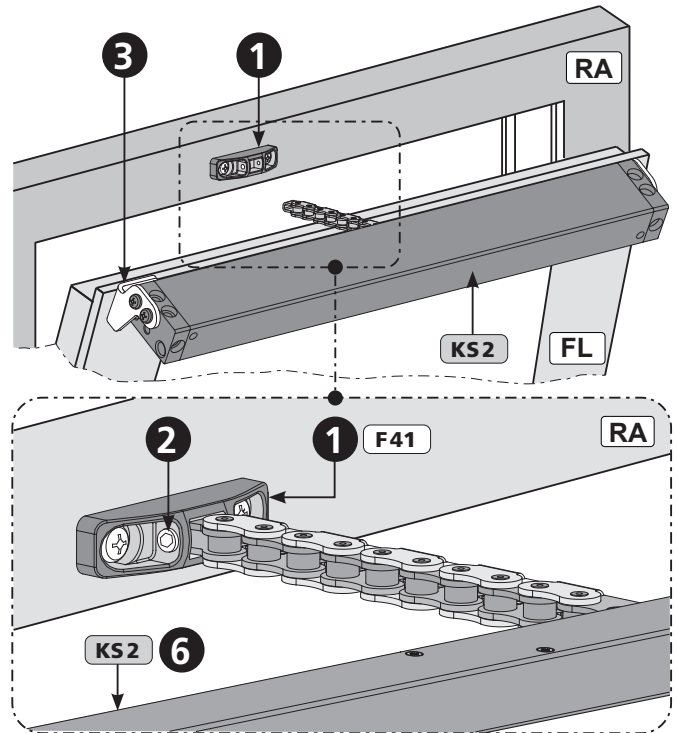

Note cable routing!  
(see chapter „CABLE ROUTING“)

Note softlauf modus!  
(see chapter „SOFT RUN MODE“)

Check swiveling area! (see chapter „AFETY CHECK AND PERFORMING TEST RUN“).

**INSTALLATION STEP 6B: RIGID DRIVE MOUNTING DIRECTLY ON THE WINDOW FRAME**  
- main closing edge or auxillary closing edge  
- inward opening windows

**HSK**  
**NSK**

- Determine fastenings.
- Produce drill holes with appropriate cross-section.  
For the mounting dimensions refer to the hole layout drawings „INSTALLATION STEPE 3 - 5“ or project-specific documents and drawings).



Carefully clear away drilling swarfs to prevent seals from being damaged.  
Avoid surface scratches, for example by using masking tape.

- Secure fasteners against loosening; e.g. by applying removable thread-locking compound such as "Loctite".

**NOTE**

Screws - for mounting on the window - are to be provided by the customer!

- Screw the KS 2 drive ① - with on-site screws (M5) - onto window frame.



Make sure they are parallel to casement edge.  
The drive body must lie completely flush on the window frame surface.

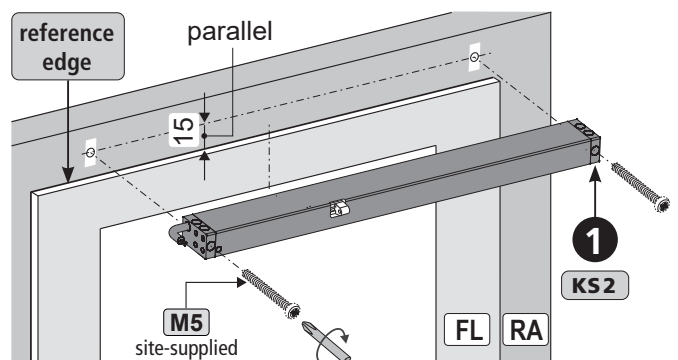

- Screw the baseplate ③ from the casement bracket F42 ② onto the casement - with on-site screws (M5).

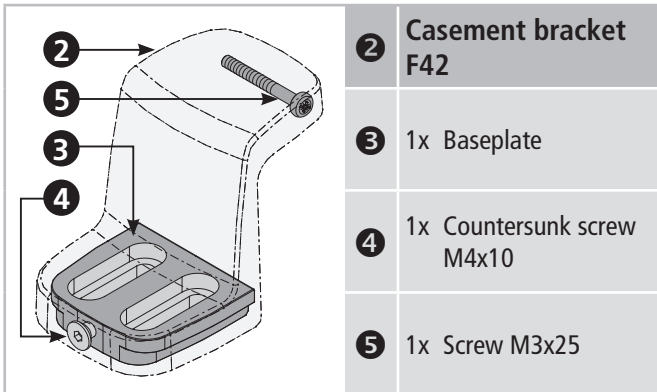

**NOTE** If necessary, use washers. These are depending on the type of screws used.

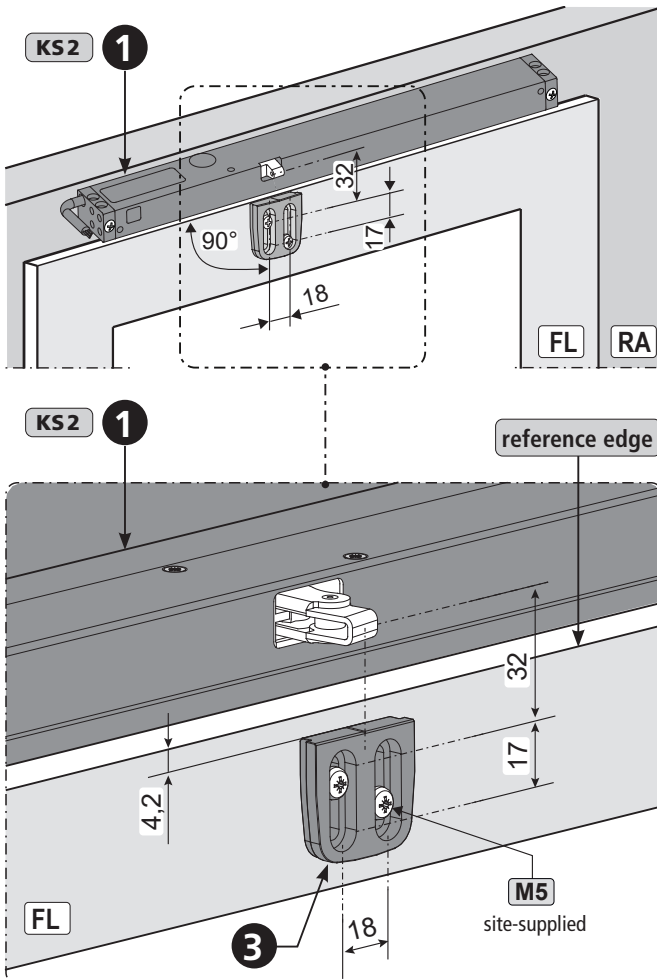

- Slide casement bracket F42 ② on the baseplate ③ and secure with screw ④.

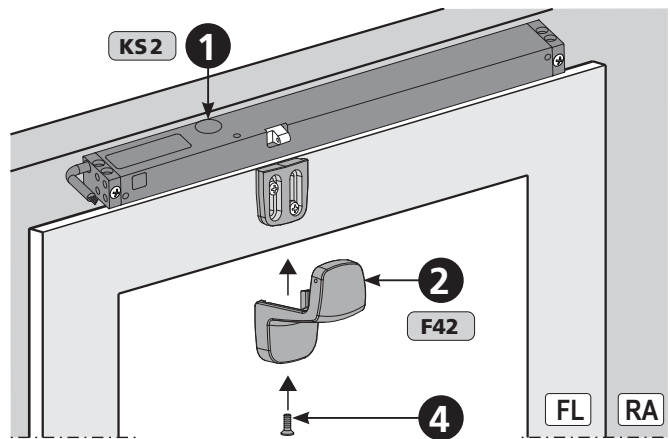

- Apply the control voltage of the KS 2 drive ① (e.g. using a tester).
- Move out the chain of KS 2 drive ① ~ 100 bis 150 mm.

**NOTE** For multi-drive operation actuate all KS 2 drives together. (see chapter: ELECTRIC CONNECTION)

- Secure the chain of KS 2 drive - with screw ⑤ - in the casement bracket F42 ②.

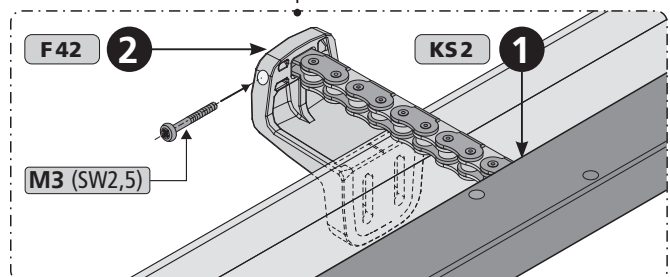
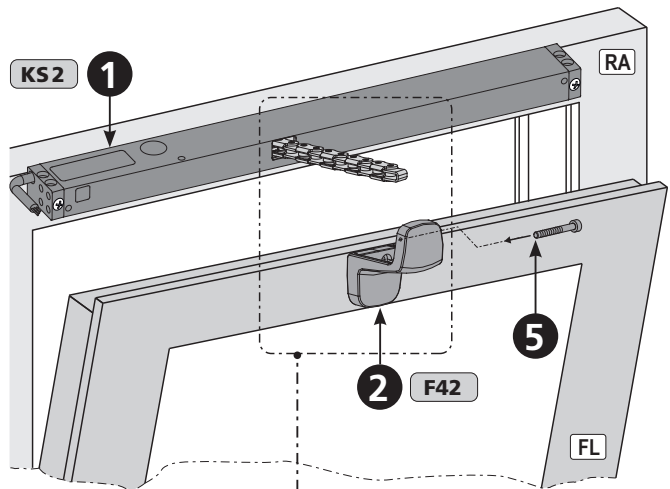

Note cable routing! (see chapter „CABLE ROUTING“)

Note softlauf modus! (see chapter „SOFT RUN MODE“)

Check swiveling area! (see chapter „AFETY CHECK AND PERFORMING TEST RUN“).



**INSTALLATION STEP 6C:** RIGID DRIVE MOUNTING DIRECTLY ON THE WINDOW FRAME  
 - main closing edge or auxiliary closing edge  
 - inward opening windows

**HSK**  
**NSK**

- Determine fastenings.
- Produce drill holes with appropriate cross-section. For the mounting dimensions refer to the hole layout drawings „INSTALLATION STEPE 3 - 5“ or project-specific documents and drawings).



Carefully clear away drilling swarfs to prevent seals from being damaged.  
 Avoid surface scratches, for example by using masking tape.

- Secure fasteners against loosening; e.g. by applying removable thread-locking compound such as "Loctite".
- Screw the **KS2** drive **1** - with on-site screws (**M5**) - onto window frame.



Make sure they are parallel to casement edge. The drive body must lie completely flush on the window frame surface.

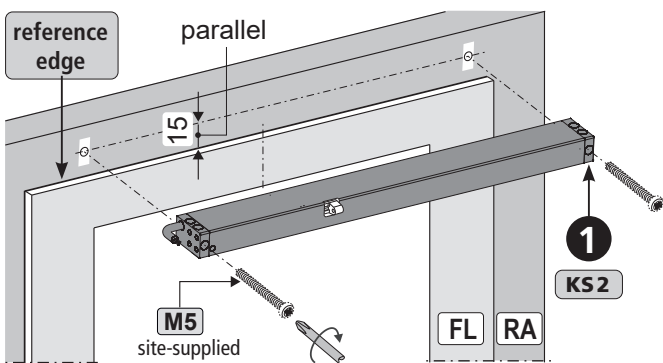

- Screw th casement bracket **F95** **2** onto the casement - with on-site screws (**M5**).

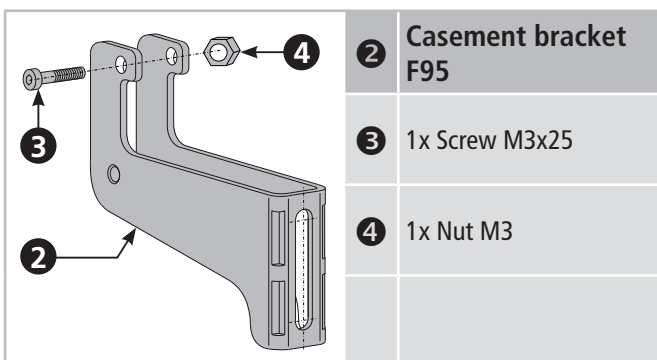

**NOTE** If necessary, use washers. These are depending on the type of screws used.

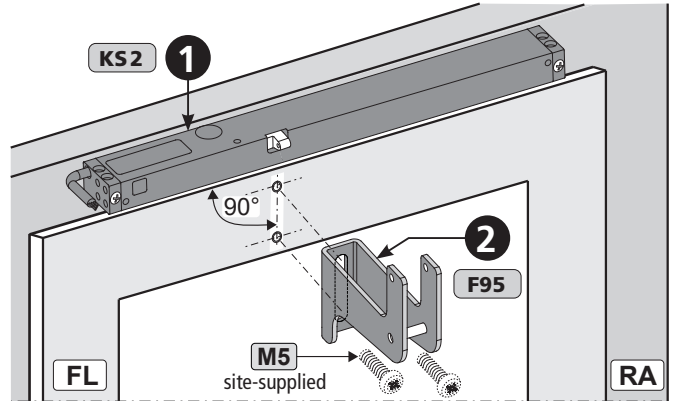

- Apply the control voltage of the **KS 2** drive **1** (e.g. using a tester).
- Move out the chain of **KS 2** drive **1** ~ 100 bis 150 mm.

**NOTE** For multi-drive operation actuate all **KS 2** drives **together**. (see chapter: ELECTRIC CONNECTION)

- Secure the chain of **KS 2** drive - with screw **3** and nut **4** - in the casement bracket **F95** **2**.

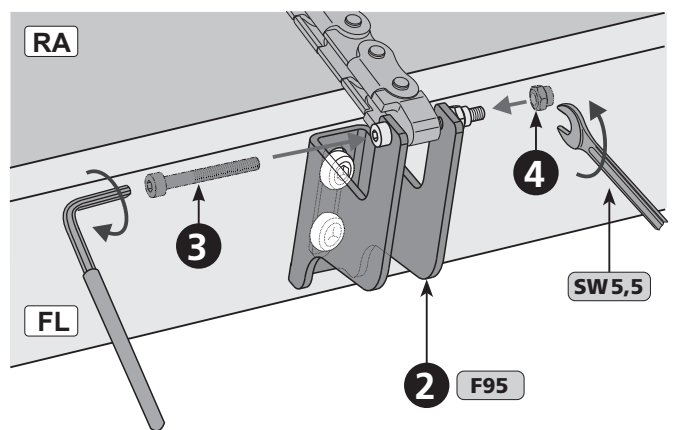

**NOTE** Note cable routing! (see chapter „CABLE ROUTING“)  
 Note softlauf modus! (see chapter „SOFT RUN MODE“)  
 Check swiveling area! (see chapter „AFETY CHECK AND PERFORMING TEST RUN“).

**INSTALLATION STEP 6D:** RIGID DRIVE MOUNTING ON THE TRANSOM  
 - main closing edge  
 - outward opening windows

**HSK**

- Determine fastenings.
- Produce drill holes with appropriate cross-section. For the mounting dimensions refer to the hole layout drawings „INSTALLATION STEPE 3 - 5“ or project-specific documents and drawings).



Carefully clear away drilling swarfs to prevent seals from being damaged.  
 Avoid surface scratches, for example by using masking tape.

- Secure fasteners against loosening; e.g. by applying removable thread-locking compound such as "Loctite".

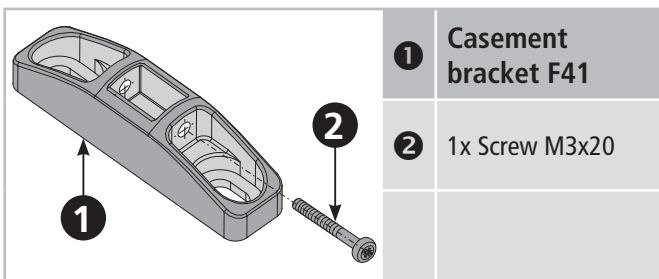

- Mount the casement bracket **F41 1** - with on-site screws (**M5**) - on the window casement.



Make sure it is parallel to casement edge.  
 „Casement bracket“ center and „chain output“ must be in line.

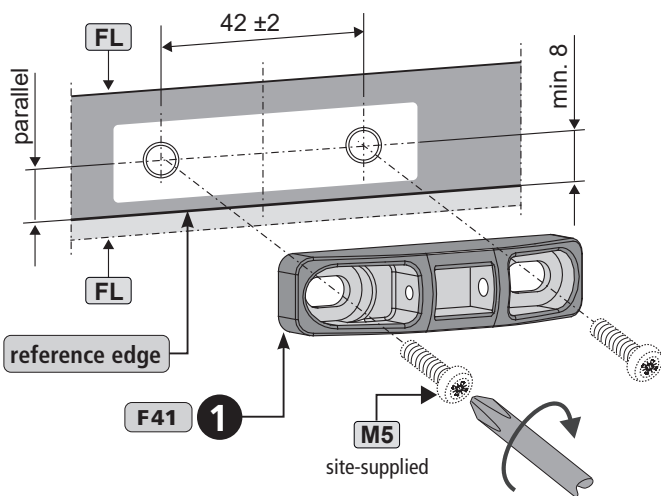

**NOTE** If necessary, use washers. These are depending on the type of screws used.

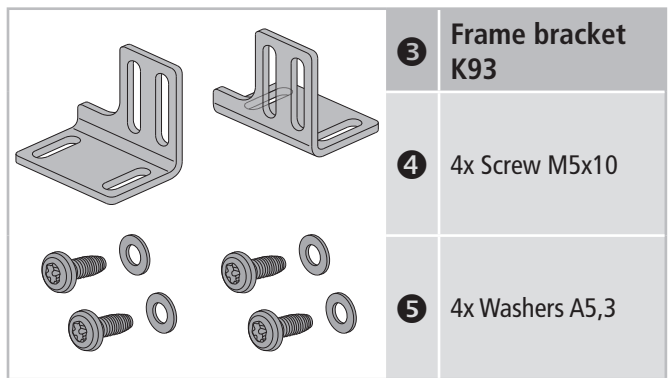

- Mount the frame brackets **K93 3** - with on-site screws (**M5**) - on the transom.



Make sure they are parallel to casement edge.

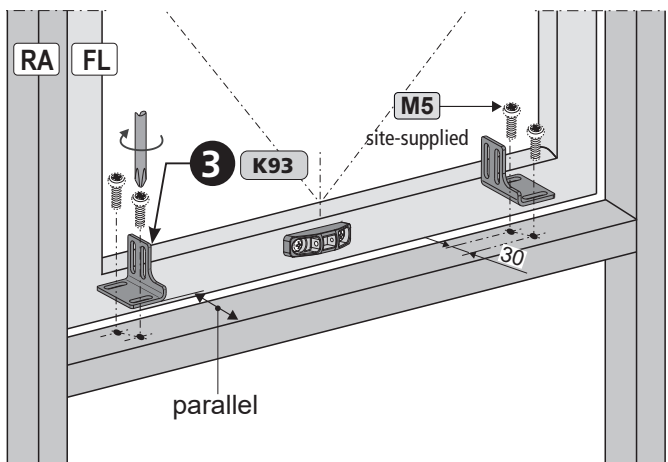

**NOTE** There are different mounting options for the frame bracket **K93 3**.

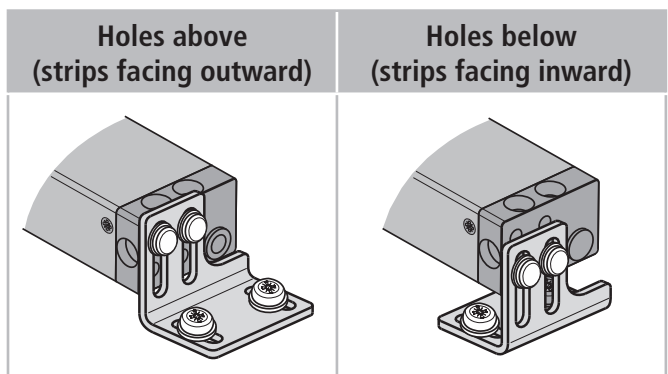



- Attache the KS 2 drive ⑥ in the frame brackets K93 ③.
- Tighten the KS 2 drive ⑥ with self-tapping screws M5 ④ and washers ⑤ (max. 4 Nm).

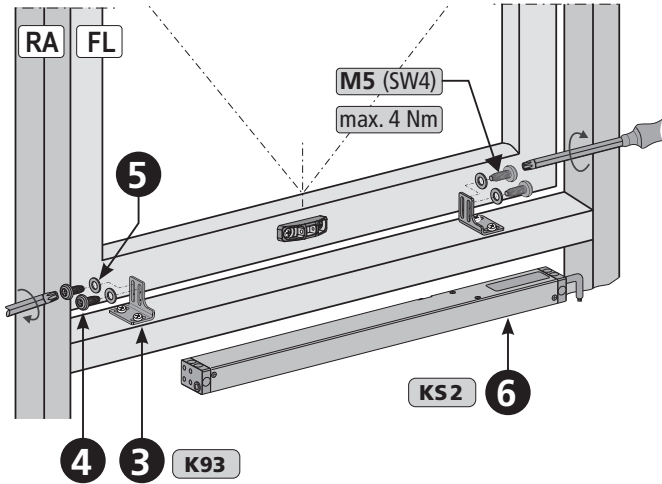

- Apply the control voltage of the KS 2 drive ⑥ (e.g. using a tester).
- Move out the chain of KS 2 drive ⑥ ~ 100 bis 150 mm.

**NOTE**

For multi-drive operation actuate all KS 2 drives together.  
(see chapter: ELECTRIC CONNECTION)

- Secure the chain of KS 2 drive - with screw ② - in the casement bracket F41 ①.

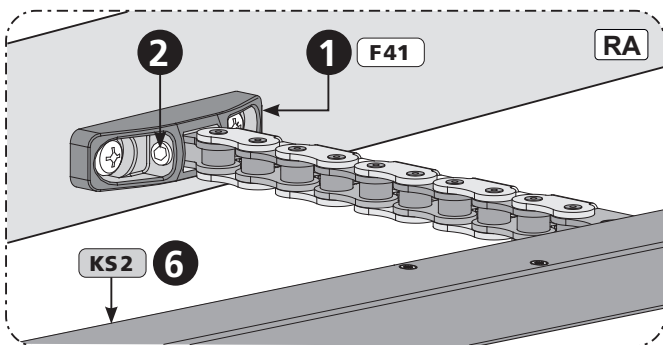

- Route the connection cable on the transom. Cable must be protected against damage (shearing-off, kinking, splitting).

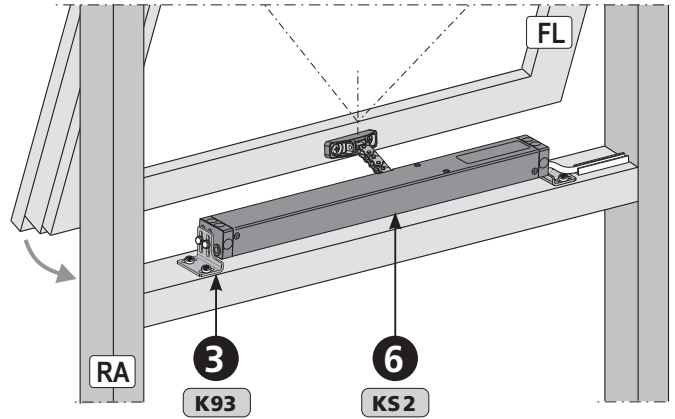

Note cable routing!  
(see chapter „CABLE ROUTING“)

Note softlauf modus!  
(see chapter „SOFT RUN MODE“)

Check swiveling area! (see chapter „AFETY CHECK AND PERFORMING TEST RUN“).



**INSTALLATION STEP 7: CABLE ROUTING - ON THE CASEMENT OR FRAME**



**Cable routing on or in the casement**

Cable on casement	Cable in glazing bead
<p>Cable duct glued on (in addition secured with countersunk screws against breaking away).</p>	<p>Drill hole in glazing bead (cable bushing protects against damage to cable).</p>
<p><b>Connection cable routing on the casement:</b></p> <ul style="list-style-type: none"> <li>• Cable must be protected against damage (shearing-off, kinking, splitting), i.e. by using bushings.</li> </ul>	

**Cable routing on the frame**

■ Route cable on the frame or transom.  
Cable must be protected against damage (shearing-off, kinking, splitting).

**Cable duct glued on** (in addition secured with countersunk screws against breaking away)

Upon removal of the glazing bead is the danger that the glass may fall.

Cable crossover <u>without</u> protective cable hose	Cable crossover <u>with</u> protective cable hose

**Connection cable routing on the hinge side:**

- Make sure that during opening or closing procedure the cable will not be damaged by shearing-off, kinking, crushing.
- Protect cable feedthrough in profile e.g. by using cable bushings, cable transitions.

## INSTALLATION STEP 8A: COVERING OF THE DRIVE

## Cover profile set AP KS2

<b>Part.-No.:</b>	523952 L = 1,5 m, incl. 2x profile bracket (*) 523954 L = 2,0 m, incl. 3x profile bracket (*) 523956 L = 2,9 m, incl. 4x profile bracket (*)
<b>Application:</b>	Cover profile for surface mounted drives KS2 with brackets K94, K129, K130. Profile length adjustable to the length of the drives (end caps recommended) or of the casement (without end caps).
<b>Material:</b>	see detailed description of componets
<b>Equipment:</b>	inclusive profile brackets, without end caps.

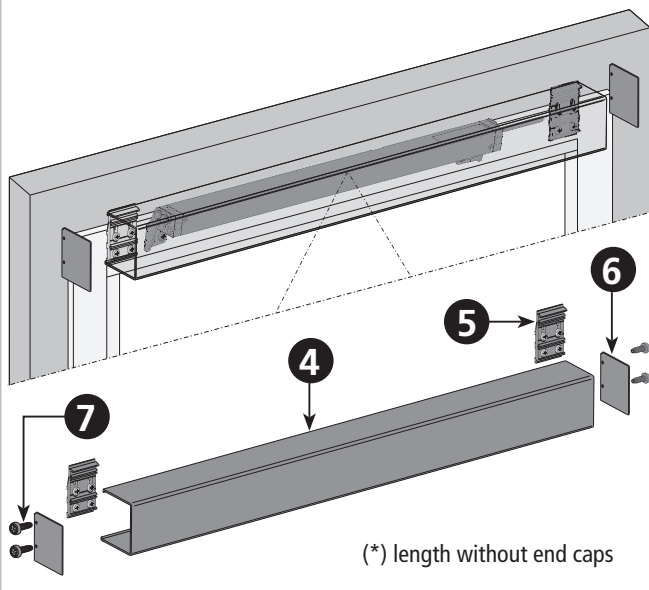

## Cover profile

<b>Part.-No.:</b>	523951
<b>Application:</b>	Cover profile for drives KS2 for cutting on site.
<b>Material / Finish:</b>	aluminium (natural anodized)
<b>Equipment:</b>	without profile brackets, without end caps

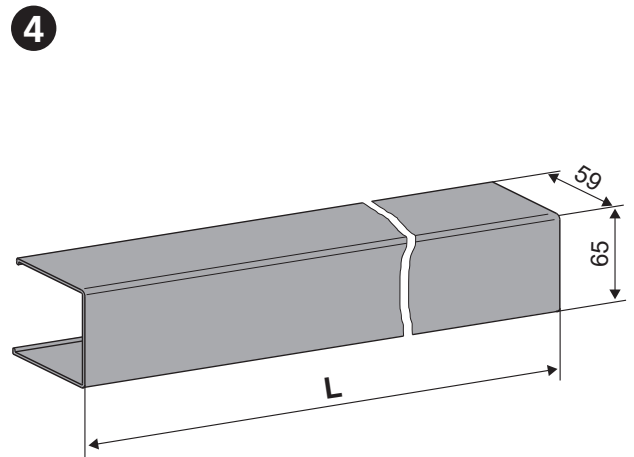

## Profile bracket

<b>Part.-No.:</b>	523948
<b>Application:</b>	Profile bracket for KS2 cover profile < 2 m length: 2 pieces > 2 m length: 3 – 4 pieces
<b>Material / Finish:</b>	aluminium (natural anodized)
<b>Equipment:</b>	1 piece (for fixing the cover profile)

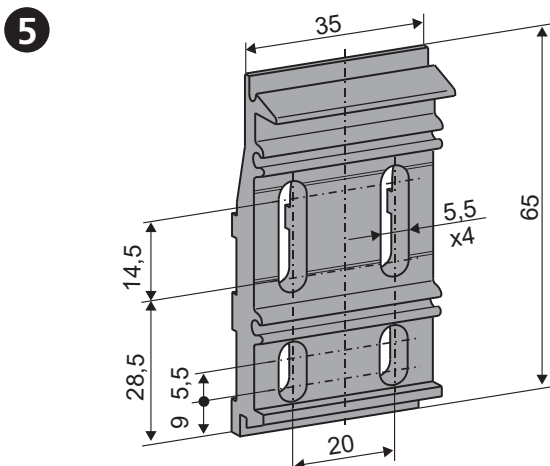

## End caps

<b>Part.-No.:</b>	523950
<b>Application:</b>	End caps for KS2 cover profile.
<b>Material / Finish:</b>	aluminium (natural anodized)
<b>Equipment:</b>	2x end caps 4x screw M3x12 (Taptite)

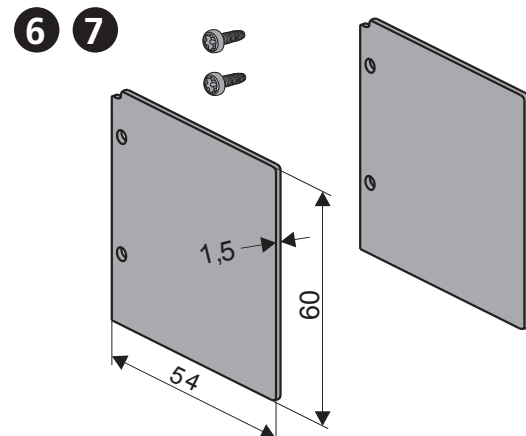

APPLICATION EXAMPLES

<p><b>Bottom hung inward opening - Casement assembly</b></p> <p><b>Y</b></p> <p>View on the steel window</p>	<p><b>Bottom hung inward opening - Casement assembly</b></p> <p><b>Y</b></p> <p>View on the aluminum window</p>
<p><b>Bottom hung inward opening - Casement assembly</b></p> <p><b>Y</b></p> <p>View on the aluminum window</p>	<p><b>Top hung outward opening - Window frame assembly</b></p> <p><b>Z</b></p> <p>View on the aluminum window</p>
<p><b>Top hung outward opening - Window frame assembly</b></p> <p><b>Z</b></p> <p>View on the aluminum window</p>	<p><b>Top hung outward opening - Window frame assembly</b></p> <p><b>Z</b></p> <p>View on the aluminum window</p>

## CUT LENGTH AND HOLE LAYOUTS

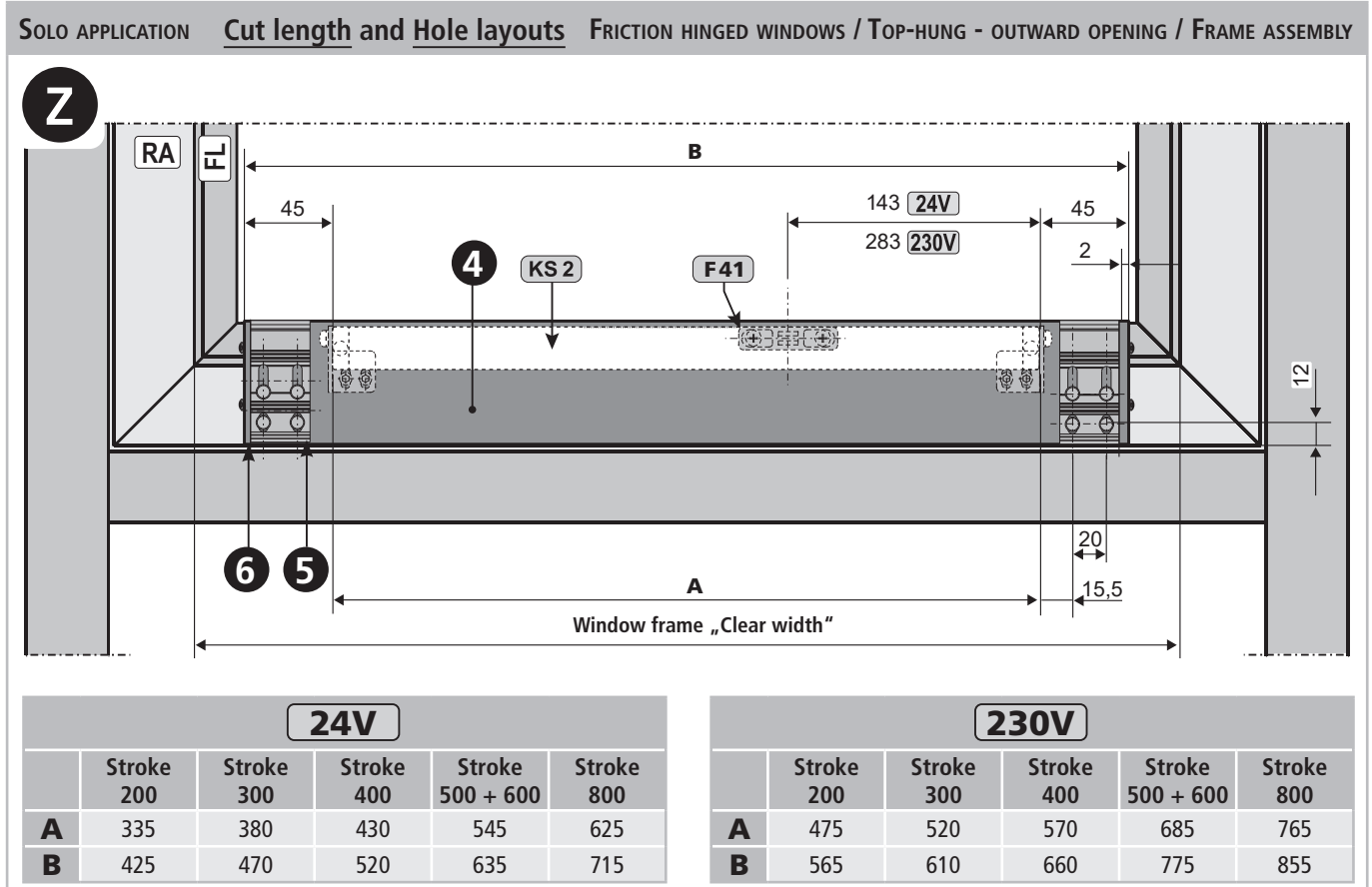
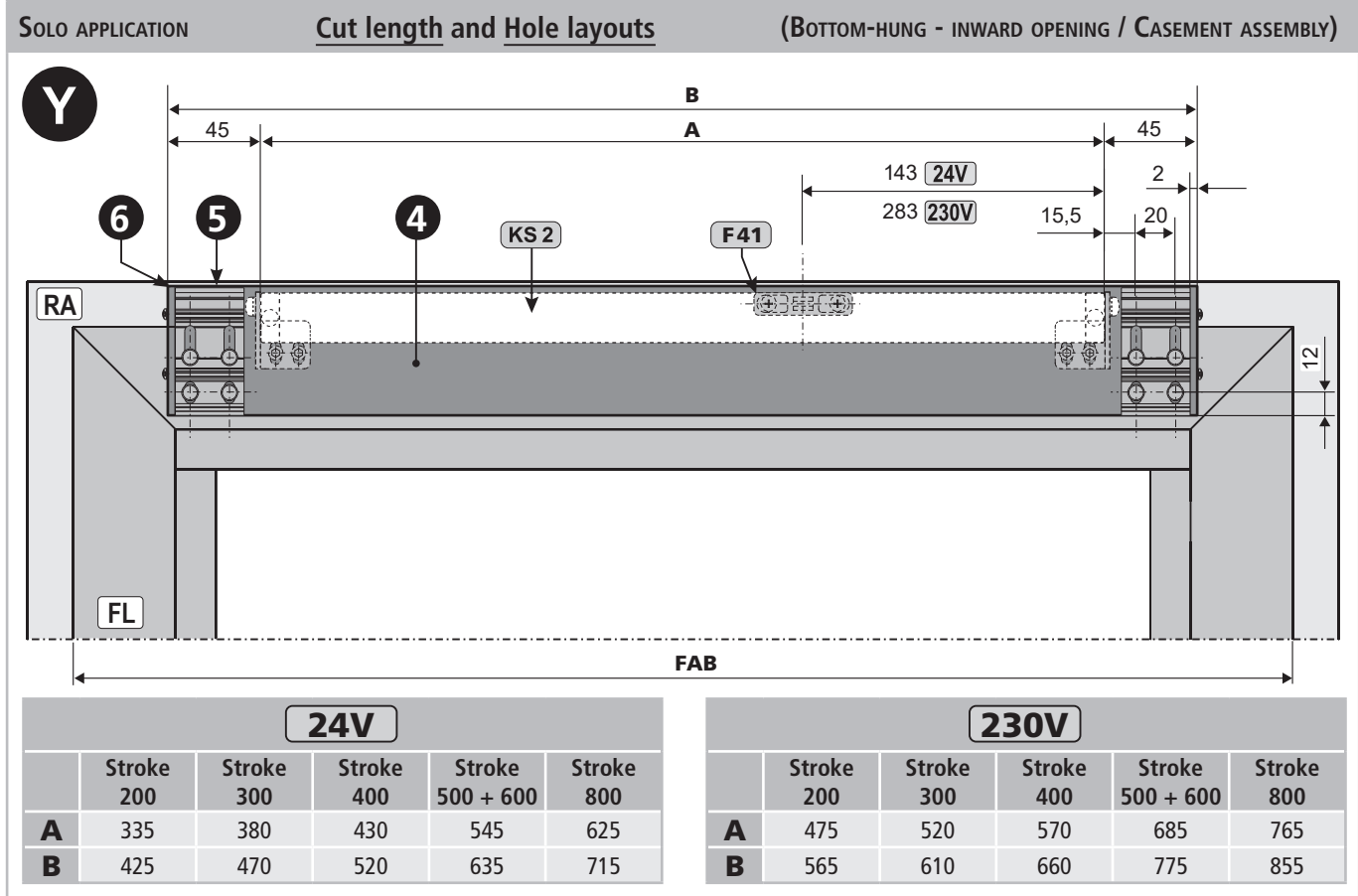

HOLE LAYOUTS

SOLO APPLICATION Cut length and Hole layouts FRICTION HINGED WINDOWS / TOP-HUNG - OUTWARD OPENING / FRAME ASSEMBLY

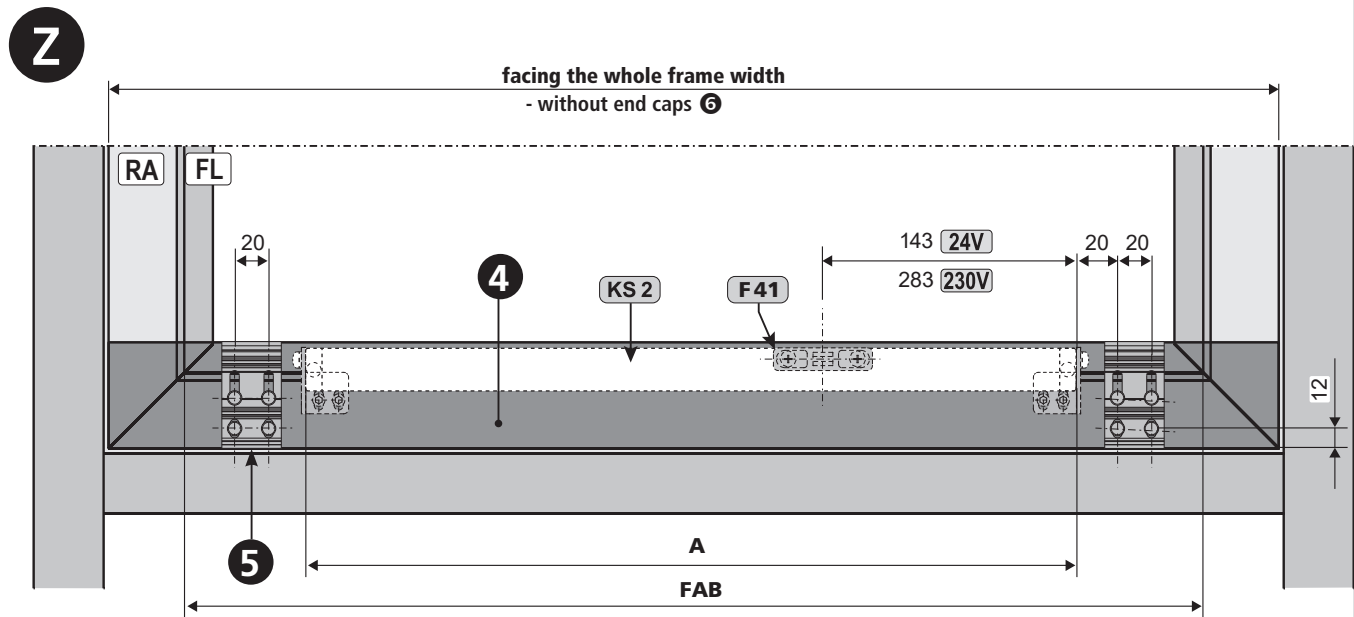

24V					
	Stroke 200	Stroke 300	Stroke 400	Stroke 500 + 600	Stroke 800
<b>A</b>	335	380	430	545	625

230V					
	Stroke 200	Stroke 300	Stroke 400	Stroke 500 + 600	Stroke 800
<b>A</b>	475	520	570	685	765

SOLO APPLICATION Cut length and Hole layouts FRICTION HINGED WINDOWS / TOP-HUNG - OUTWARD OPENING / FRAME ASSEMBLY

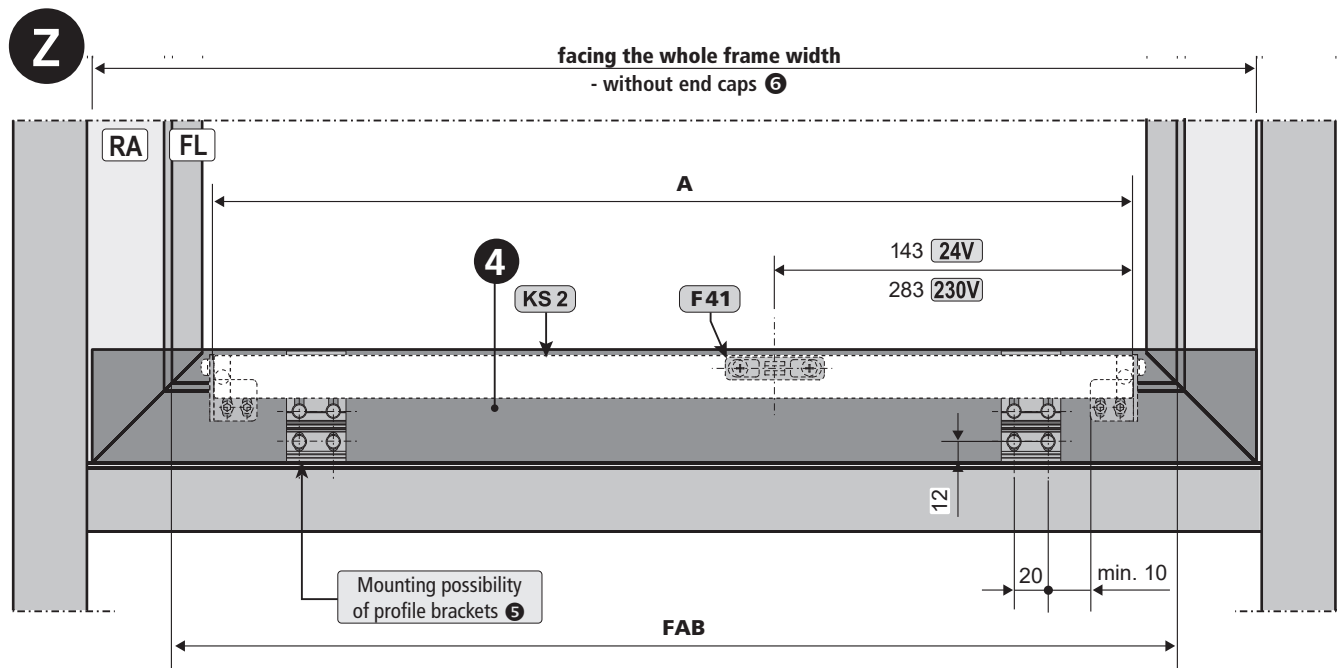

24V					
	Stroke 200	Stroke 300	Stroke 400	Stroke 500 + 600	Stroke 800
<b>A</b>	335	380	430	545	625

230V					
	Stroke 200	Stroke 300	Stroke 400	Stroke 500 + 600	Stroke 800
<b>A</b>	475	520	570	685	765

## INSTALLATION STEP 8B: INSTALLING THE COVER PROFILE

- Determine fastenings.
- Produce drill holes with appropriate cross-section. For the mounting dimensions refer to the hole layout drawings „INSTALLATION STEPE 8“.

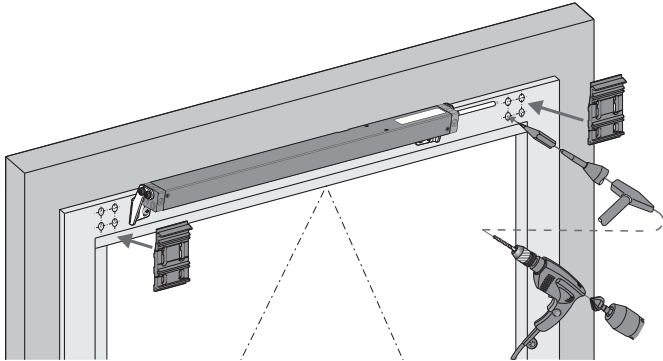

Carefully clear away drilling swarfs to prevent seals from being damaged. Avoid surface scratches, for example by using masking tape.

- Screw on profile brackets 5.  
Number of profile brackets 5 depends on the length of the cover profile 4:  
< 2 m length = 2 pieces  
> 2 m length = 3 - 4 pieces

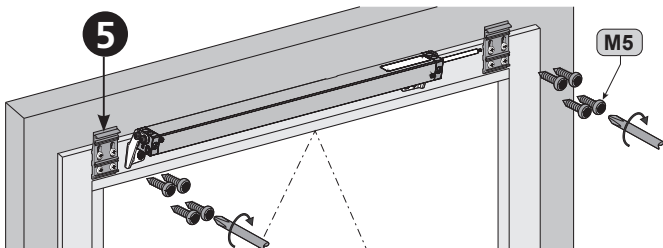

- Determine length of cover profile 4:  
 $\text{Length cover profile 4} = \text{total distance between the profile brackets 5 (outer edge)} + 4 \text{ mm}$ .
- Use a saw to shorten the cover profile 4 to the required length.
- Deburr saw cut edge.



Ensure that you saw the profile perpendicular.

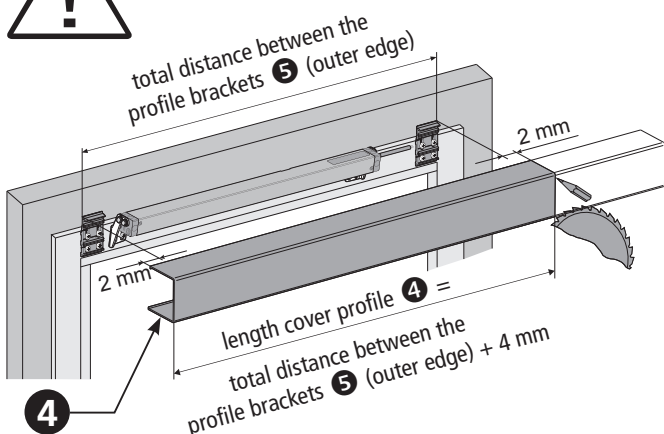

- Align the cover profile 4 on the profile brackets 5 proportionally and centrally and fit.

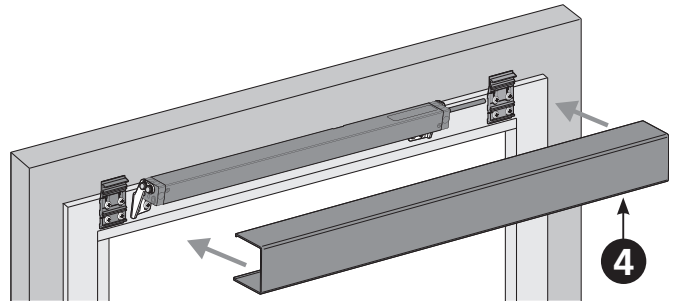

### NOTE

Ensure the correct positioning of the cover profile 4 (short side facing upwards).

### Top hung / projecting top-hung casement - outward opening

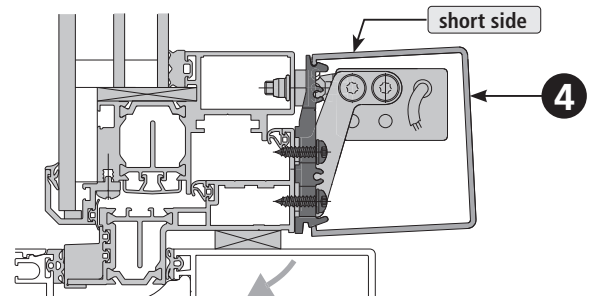

### Bottom-hung casement - inward opening

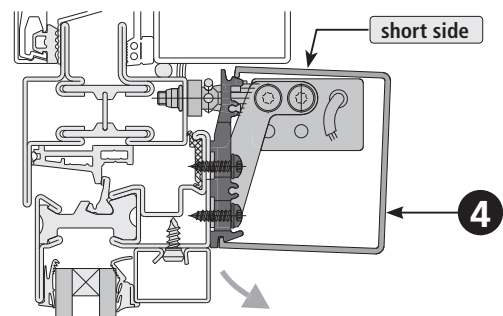

- Attach end caps 6 and with screw M3 7 fasten.

### NOTE

Open casement electrically if appropriate (to have a better access to the screws 7).

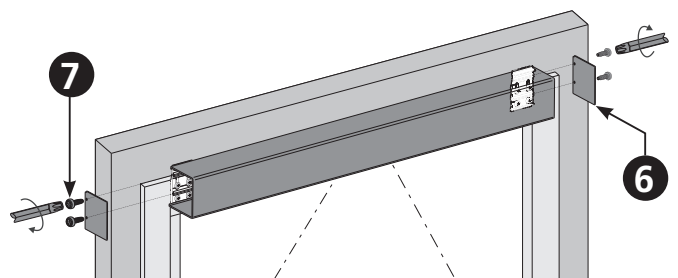

The end cap 6 fit exactly into the cover profile 4 and form a flush edge. In the case of covers between post and post end caps 6 are not required.

## INSTALLATION STEP 9: ELECTRIC CONNECTION



Make sure when establishing the connection that there is no voltage at the terminals!  
Unused wires must be safely insulated!

The running direction of the 24V-drive may be changed by interchanging (polarity reversal) the wires „BN - (brown)” - „BU - (blue)”.

Wire colour coding		Direction of travel
Finish	DIN IEC 757	
black	BK	OPEN
white	WH	CLOSE
brown	BN	
blue	BU	Polarity reversal
green / yellow	GN / YE	
green	GN	
violet	VT	
grey	GY	

**Connection assignment: KS 2 (24V)** **24V**

<b>BN</b>	<b>+</b>	<b>-</b>
<b>BU</b>	<b>-</b>	<b>+</b>

WH is used for communication (in systems with synchronized multi-drive operation - S12 drive)

**GN / VT:** Version Z (CLOSE)  
Contact: max. 24V, 500 mA (min. 10 mA)

**Connection assignment: KS 2 (230V)** **230V**

	<b>OPEN</b>	<b>CLOSE</b>
<b>L</b>	<b>BN</b>	<b>BK</b>

**GN / YE = PE**  
**BU = N**

**GY / WH:** Version Z (CLOSE)  
Contact: max. 24V, 500 mA (min. 10 mA)

No synchronized multi-drive operating possible!

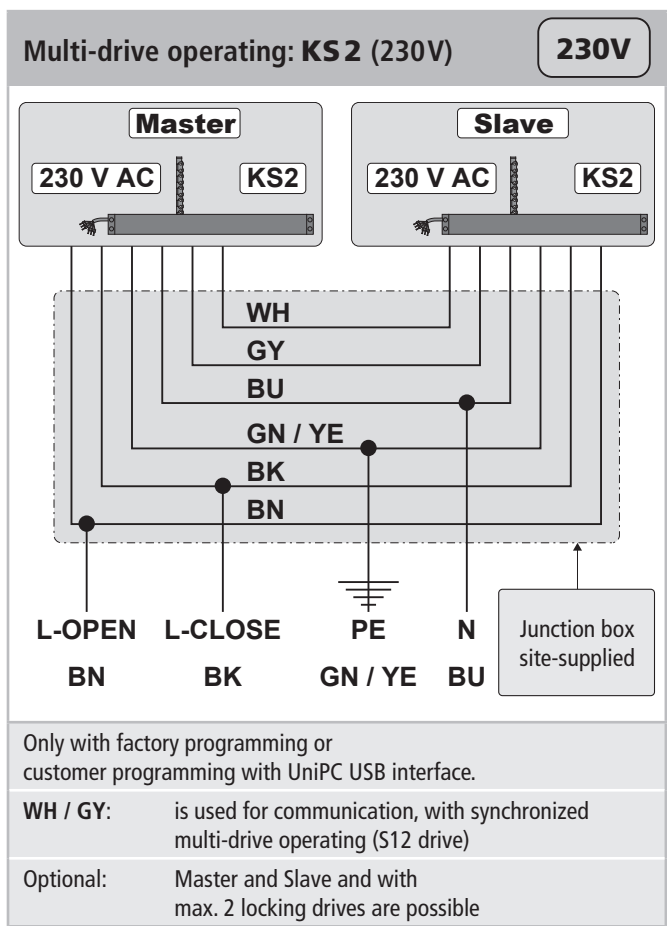
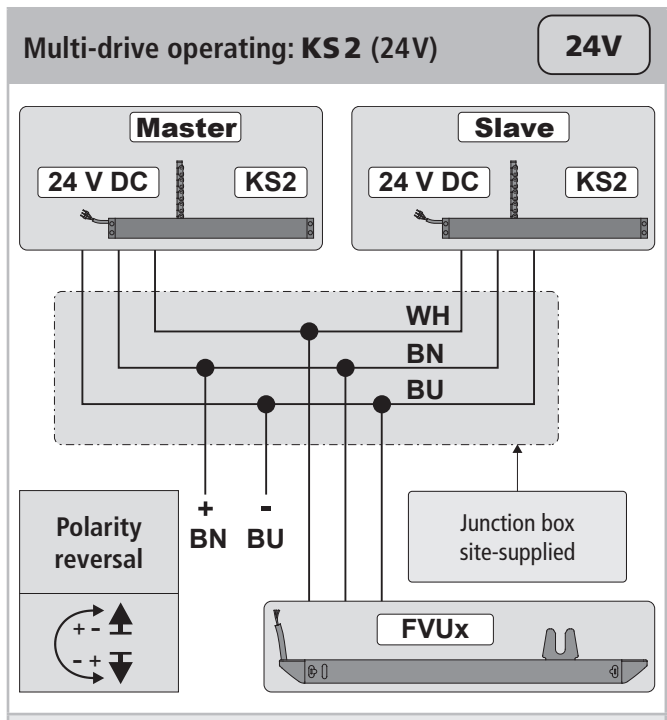



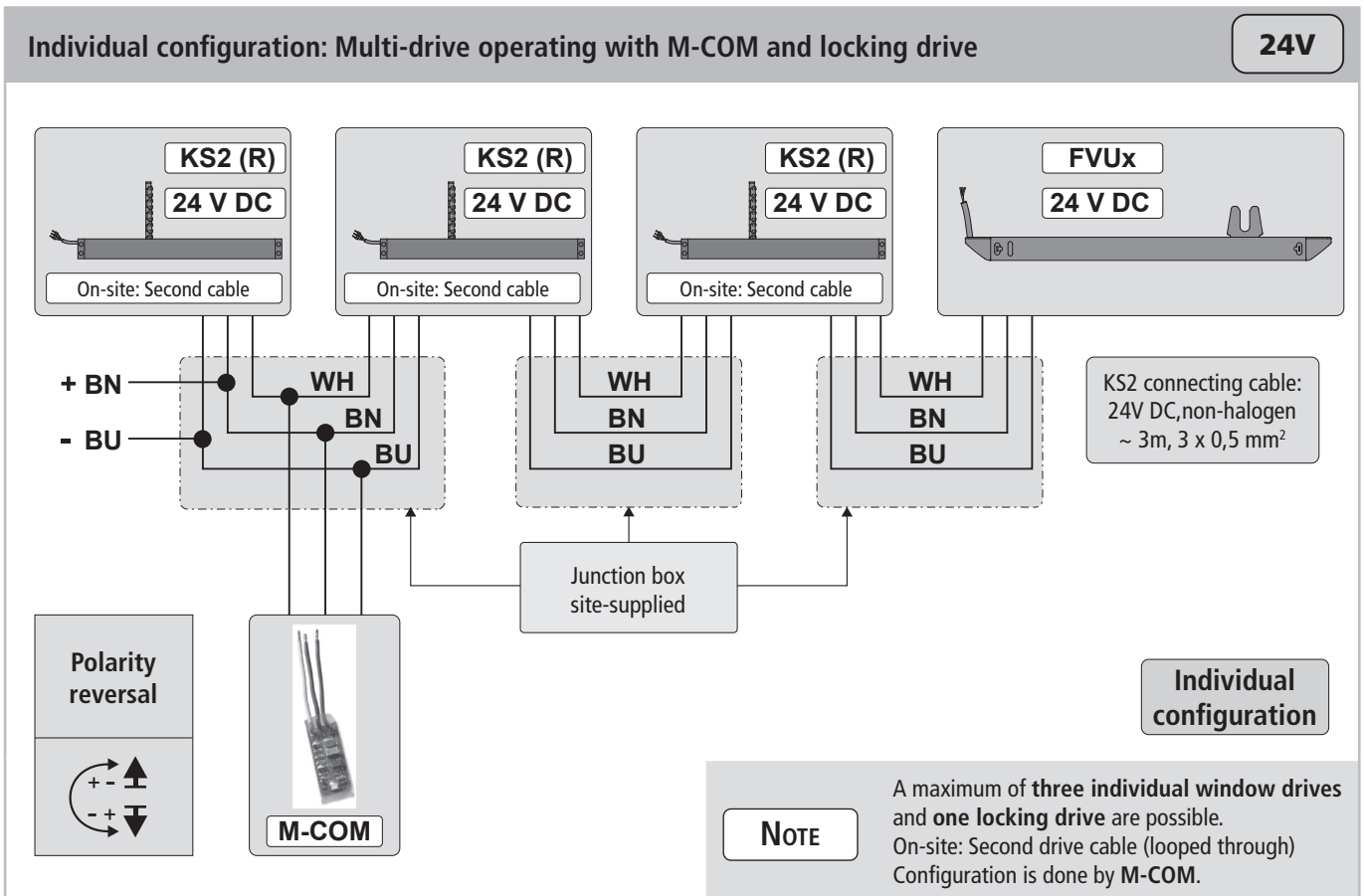
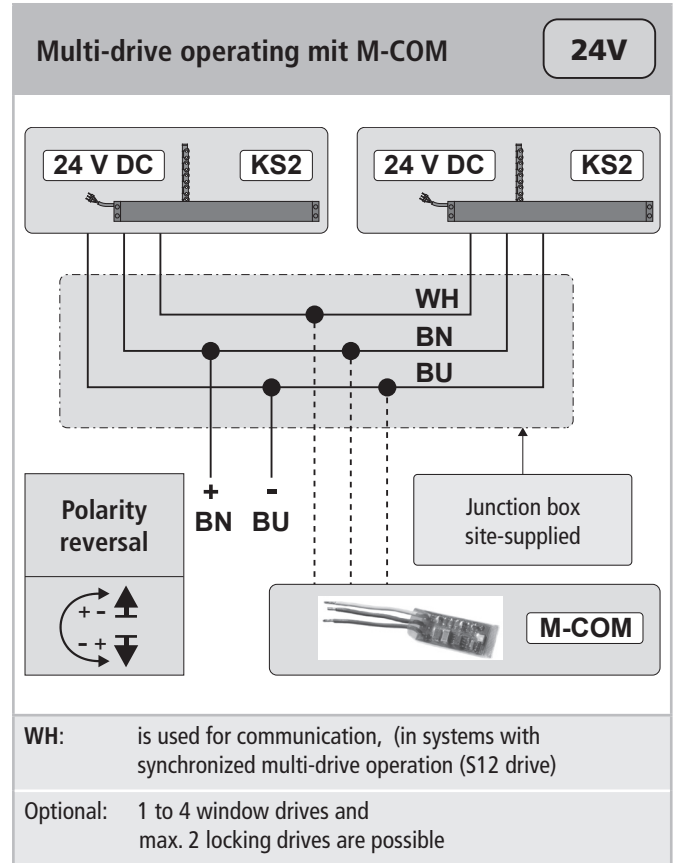
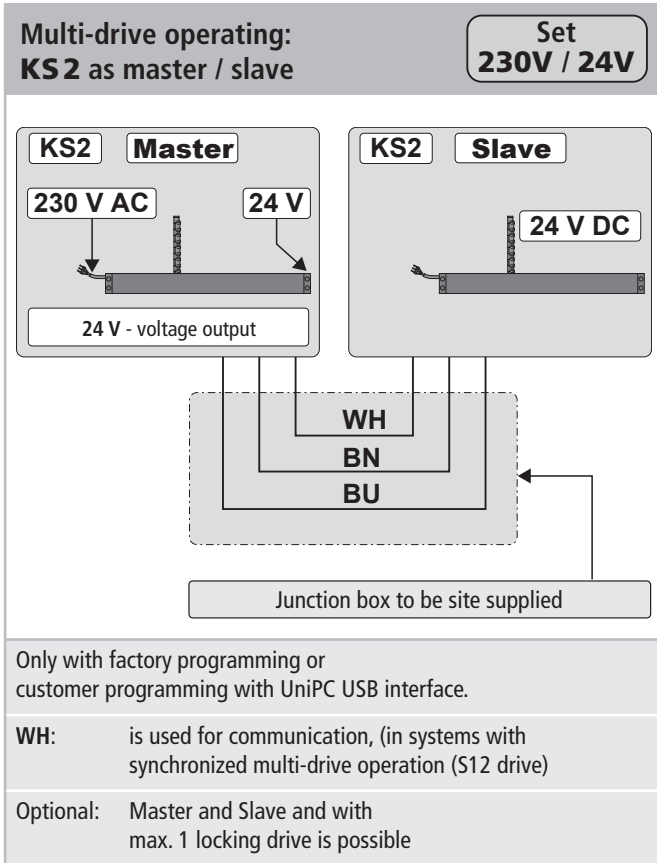

Multi-drive operating: Window drive „Set A“ with M-COM and locking drive

230V/24V

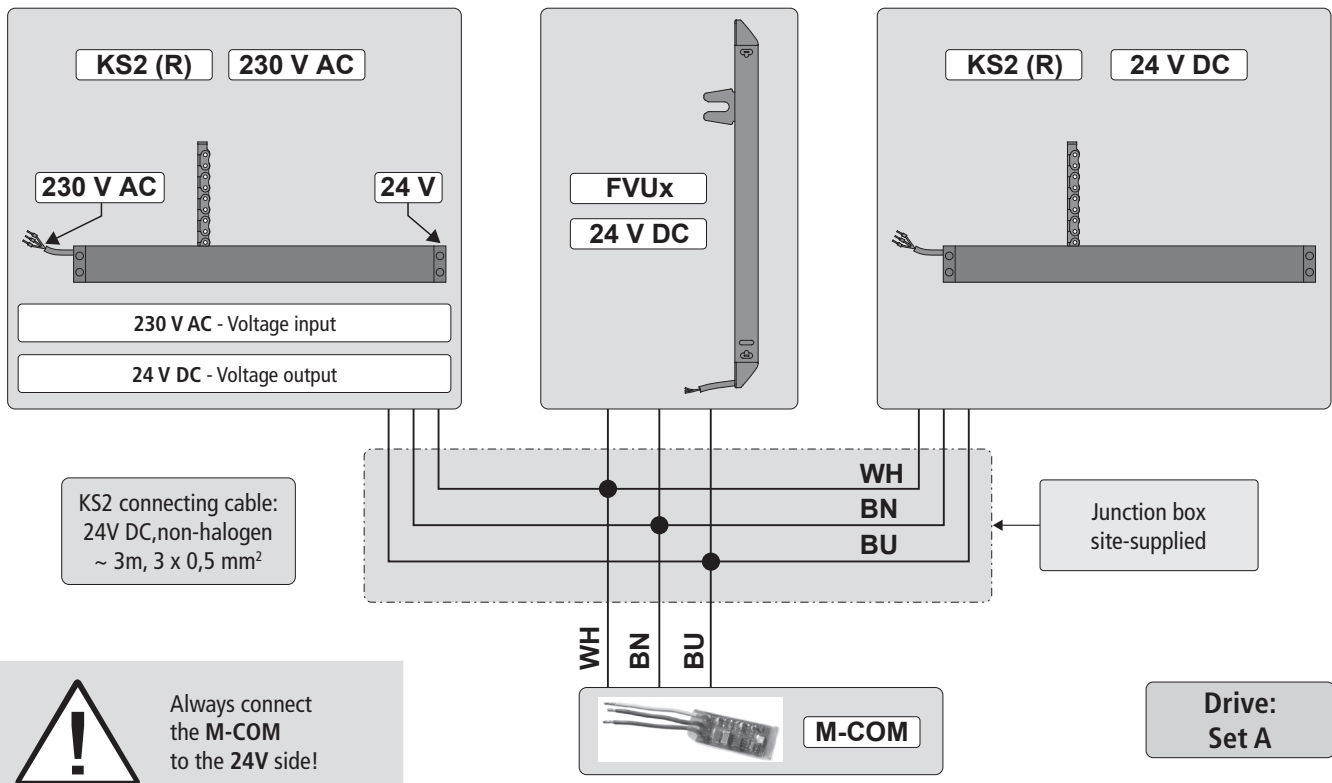

**NOTE**

The drive „Set A“ is a factory configured set.  
Included in the delivery are:  
Master: KS2 S12 230V AC R with voltage output 24V DC  
Slave: KS2 S12 24V DC R with connecting cable on the engine side

Options:  
Programmable special functions and sequence control with locking drives.  
Configuration is done by M-COM.

**M-COM (Main control unit)****24V**

<b>Order number:</b>	524177
<b>Application:</b>	Configuration module for the automatic configuration and monitoring of max. 4 opening and 2 locking drives type S12 / S3 in multi-drive systems.
<b>Rated voltage:</b>	24V DC +/- 20%, (max. 2 Vss)
<b>Current consumption:</b>	<12 mA
<b>Drive type:</b>	S12
<b>Protection class:</b>	IP30 rubber jacket
<b>Ambient temperature:</b>	0 °C ... + 70 °C
<b>Dimensions:</b>	45 x 17 x 6 mm
<b>Connecting wires:</b>	3 wires 0,5 mm <sup>2</sup> x 50 mm

**Feature / Equipment:**  
printed circuit board with connecting wires for integration in site-supplied junction box.

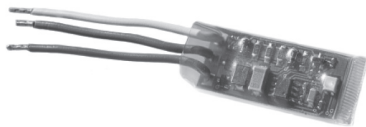
**UniPC with configuration interface****24V****230V**

<b>Order number:</b>	524178
<b>Application:</b>	Hard- and software for configuration of drives supplied by AUMÜLLER GmbH
<b>Rated voltage:</b>	24V DC +/- 20%
<b>Parameterizable drives:</b>	24V DC type S3, S12 230V AC type S12
<b>Scope of delivery:</b>	software UniPC (Downloadlink*), Interface "ParInt", USB cable, connection cable * <a href="http://www.aumuller-gmbh.de/Downloads">http://www.aumuller-gmbh.de/Downloads</a>

**Features / Equipment:**  
Power supply 24V DC is not included in the scope of delivery!  
Any extended settings require a software licence.



Any reconfiguration of a drive is entirely at the user's own risk and responsibility.

**Cable junction box (for renewal)****24V**

<b>Order number:</b>	513344
<b>Application:</b>	to extend a drive cable
<b>Rated voltage:</b>	only for low voltage to max. 50V DC/AC
<b>Material:</b>	stainless steel (V2A)
<b>Protection class:</b>	IP 40
<b>Dimensions:</b>	25 x 27 x 150 mm
<b>Equipment:</b>	with cable gland (grey) including strain relief, with loose ceramic terminals.

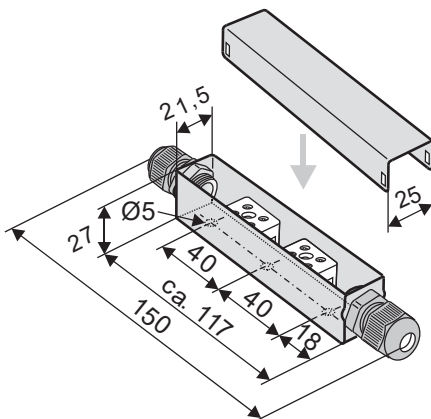

## INSTALLATION STEP 10: SUPPLY LINES OF CONTROL UNIT TO THE DRIVES

Observe current regulations and guidelines regarding the "Fire behavior of building materials-circuit integrity maintenance of electric cable systems" (E30, E60, E90) and the prescribed constructional regulations!

**RECOMMENDATION** For safety reasons a cable of the next higher wire cross section should be selected.

**Formula to calculate**  
the required wire cross-section of a supply line

24V

$$A \text{ mm}^2 = \frac{I_A \text{ (total)} * L_m \text{ (length supply line)} * 2}{2,0V \text{ (voltage drop)} * 56 \text{ m} / (\Omega * \text{mm}^2)}$$

### Calculation example

Available data:

- cut-off current per drive (i. e. 2 x 4.0A) from data sheet
- length to be bridged from the last window to the control unit (i. e. 10 meters)

$$A = \frac{(2 * 4,0A) * 10m * 2}{2,0V * 56m / (\Omega * \text{mm}^2)}$$

$$A = 1,42\text{mm}^2 \rightarrow 1,5\text{mm}^2 \text{ chosen}$$

## Laying and connecting the drive cable

- Avoid extreme temperature differences in the installation area (danger of condensation).
- Set clamping point close to window and ensure accessibility.
- Ensure expansion possibilities of the drive and the drive cable.
- Consider the cable length and the cross sections of the drives supply lines.

## INSTALLATION STEP 11:

### SOFT RUN MODE

#### Soft run setting for drives with S12

The drive has an electronic position detection. Just before the CLOSED position the chain retracts with reduced speed in the soft run mode, to protect the window and the drive.

- In soft run mode the zero-point - and thus the CLOSE-position of the window - is recognized.
- The drives with **S12** must turn off in the soft run range (about 40 mm in front of the CLOSE-position).
- In closing direction in case of overload outside the 40 mm soft run range, the chain moves out by approximately 10 mm.

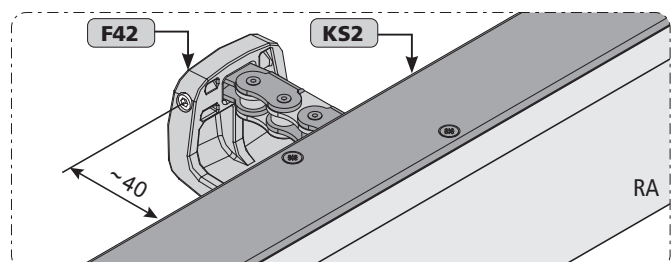
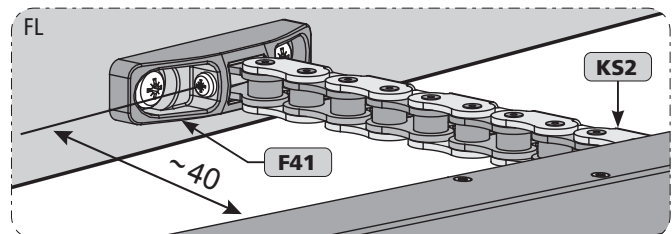

## INSTALLATION STEP 12: SAFETY CHECK AND TEST RUN

Check the mounted system for its safety; perform test run and commissioning.

### Safety test:

- Connect operating voltage.
- Check fastening (frame brackets, casement brackets) for firm fit or tightening.

### Test run:

- Visual inspection of casement movements.
- Stop immediately by malfunction!
- Pay attention to collision with facade construction and correct installation, if required.

### Risk evaluation:

Before operating a power-operated window to which window drives were mounted, which were sold by the manufacturer as incomplete machines according to installation declaration, the possible risk to hazard of persons must be determined, evaluated and minimized by taking appropriate technical measures in accordance with the Machinery Directive. Separate documents for performing a risk assessment can be downloaded from the homepage of

**Firm AUMÜLLER AUMATIC GmbH**  
([www.aumueller-gmbh.de](http://www.aumueller-gmbh.de)).

## Operation of the power-operated window

When operating the power-operated window safety instructions must be observed, specifically those pertaining to commissioning, operation and maintenance.

## HELP IN CASE OF MALFUNCTIONS, REPAIRS AND MAINTENANCE

Professional repair of a defect drive can only be performed at the manufacturer's factory or manufacturer-certified specialist company. Unauthorized opening or manipulation of the drive terminates warranty.

1. Exchange defect drives or have them repaired by the manufacturer.
2. In case of problems during installation or normal operation the following table might be useful:

Problem	Possible causes	Possible solutions
Drive does not start	<ul style="list-style-type: none"> <li>• Duration of mains power supply too short</li> <li>• Drive run direction not correct</li> <li>• Connecting cable not connected</li> <li>• Power supply / Control Unit voltage incorrect, too high or too low (see data sheet)</li> <li>• No mains supply to power supply unit / Control Unit (no voltage)</li> <li>• Drive has shut down on overload</li> </ul>	<ul style="list-style-type: none"> <li>• Adjust supply voltage as specified in the technical documentation</li> <li>• Check drive cables</li> <li>• Check all connection cables</li> <li>• Check power supply unit and replace if necessary</li> <li>• Connect power supply</li> <li>• First move drive in CLOSE position</li> </ul>
Drive doesn't start after having been in operation several times	<ul style="list-style-type: none"> <li>• Operating time has been exceeded, drive has been overheated</li> <li>• See possible solutions above associated with „Drive doesn't start“</li> </ul>	<ul style="list-style-type: none"> <li>• Wait until drive has cooled down and start again</li> <li>• See possible solutions associated with: "Drive doesn't start"</li> </ul>
Drive doesn't close	<ul style="list-style-type: none"> <li>• Closing edge safety mechanism has been triggered (if existing)</li> <li>• See possible solutions above associated with „Drive doesn't start“</li> </ul>	<ul style="list-style-type: none"> <li>• Release safety area for operation and reset closing edge safety mechanism</li> <li>• See possible solutions associated with: "Drive doesn't start"</li> </ul>
Drive travels uncontrolled in open and close direction	<ul style="list-style-type: none"> <li>• Residual ripple of power supply / control unit too high</li> <li>• Fault in power supply unit / control unit</li> </ul>	<ul style="list-style-type: none"> <li>• Adjust drive voltage to the required value of drive. (values see data sheet of drive)</li> <li>• Check output voltage of power supply unit or control unit</li> </ul>
Drive closes, but after about 10 mm the drive open	<ul style="list-style-type: none"> <li>• Close the window outside the 40 mm (Soft run mode).</li> </ul>	<ul style="list-style-type: none"> <li>• Drive mounted so, that the closing process takes place within the 40 mm (e.g. use spacer under the casement bracket).</li> </ul>

## MAINTENANCE AND MODIFICATION

To ensure continuous function and safety of the drive periodic maintenance by a specialist company is required at least once a year (as mandated by law and recommended by manufacturer). Operational readiness must be checked regularly. Frequent inspection of the system for imbalance and signs of wear or damages of cables and fastening elements must be performed.

During maintenance contaminations must be removed from the drive. Fastenings and clamping screws must be checked for tightness. Test runs during the opening and closing procedure of the devices must be performed.

The drive itself is maintenance-free. Defect devices may only be repaired in our factory. Only spare parts of the manufacturer may be used. When the connection cable of this device is damaged it must be replaced by the manufacturer or his customer service or a similarly qualified person to avoid endangerment.

It is recommended to conclude a maintenance contract. A sample maintenance contract can be downloaded from the homepage of

**Firm AUMÜLLER AUMATIC GmbH**  
([www.aumueller-gmbh.de](http://www.aumueller-gmbh.de)).

While cleaning the windows, drives may not have direct contact with water or cleaning agents. Drives must be protected from dirt and dust during the construction phase or renovations.

### Maintenance process

1. Open or extend power-operated casement completely.
2. Completely disconnect the system from the mains and secure it against automatic or manual activation.
3. Check windows and fittings for damages.
4. Check all mechanical fastenings (if required, observe information on torques in installation instructions).
5. Check electric drives for damages and contaminations.
6. Check connecting cables (drive cable) for:
  - tightness of the cable screw
  - functionality of the strain relief
  - damages
7. Check the mobility of hinges and fittings and re-adjust or apply lubricant, e.g. silicone spray (observe the instructions of the manufacturer of this window system).
8. Check peripheral seal, remove contaminations or replace.
9. Perform cleaning to maintain functionality (e.g. clean extending elements of the drive, such as chains or spindles by damp wiping them with acid or lye-free agents and drying them and, if required, lubricate them with cleansing oil e.g., Ballistol).
10. Turn on operating voltage.
11. Open and close the power-operated window via the operating voltage (functional test).
12. If available, check and re-adjust protection systems of the safe guard fixture.
13. Check the intactness of the CE label at the power-operated system.
14. Check the intactness of warning instructions and labels at the respective drive.
15. Perform a risk assessment in accordance with Machinery Directive 2006 / 42 / EG, if required, e.g. after modifying the machine.

## DEMOUNTING

The drives are demounted by reversing the steps, as for the installation. The adjustments are omitted.

1. Completely disconnect the system from the power supply before demounting a drive.
2. After demounting a drive the window must be secured against independent opening.

Dispose of parts according to the locally applicable legal provisions.

## DISPOSAL

According to the European Directive 2012/19 / EU on Waste Electrical and Electronic Equipment (WEEE) and its transposition into national law, obsolete electrical appliances must be collected separately and sent for environmentally friendly recycling.



## LIABILITY

We reserve the right to change or discontinue products at any time without prior notice. Illustrations are subject to change. Although we take every care to ensure accuracy, we cannot accept liability for the content of this document.

## WARRANTY AND CUSTOMER SERVICE

In principal apply our:

„General Terms for the Supply of Products and Services of the German Electrical Industry (ZVEI)“.

The warranty corresponds with legal provisions and applies to the country in which the product has been acquired.

The warranty includes material and manufacturing defects incurred during normal use.

The warranty period for delivered material is twelve months.

Warranty and liability claims for personal injuries or material damages are excluded, if caused by one or more of the following:

- No proper incoming goods inspection.
- Improper use of the product.
- Improper installation, commissioning, operation, maintenance or repair of the product.
- Operating the product by defect and improper installed or not functioning safety and protection devices.
- Ignoring instructions and installation requirements in these instructions.
- Unauthorized constructional modifications at the product or accessories.
- Disaster situations due to effects of foreign bodies and Acts of God.
- Wear and tear.

Contact persons for possible warranty claims, for spare parts or accessories are the employees of the responsible branch office or the responsible person at

**Firm AUMÜLLER AUMATIC GmbH.**

Contact data are available at our homepage

([www.aumueller-gmbh.de](http://www.aumueller-gmbh.de))







### CERTIFICATE AND DECLARATION OF CONFORMITY

We declare under our sole responsibility that the product described under "Data sheet" is in conformity with the following directives:

- 2014/30/EU  
Directive relating to Electro-Magnetic Compatibility
- 2014/35/EU  
Low voltage Directive



We further declare that the drive is an incomplete machine within the meaning of the European Machinery Directive (2006/45/EG).

Technical file and declaration at firm:

**AUMÜLLER AUMATIC GmbH**  
Gemeindewald 11  
D-86672 Thierhaupten

Ramona Meinzer  
Managing Director (Chairman)

#### NOTE:

The proof of the application of a quality management system is for company:

**AUMÜLLER AUMATIC GmbH**  
according to the certification basis **DIN EN 9001** as well the "Declaration of Incorporation and Conformity" can be accessed via the QR code or directly on our homepage:  
**(www.aumueller-gmbh.de)**



#### TRANSLATION OF THE ORIGINAL INSTRUCTIONS (GERMAN)

##### Important note:

We are aware of our responsibility, which is why we present life-supporting and value-preserving products with greatest possible conscientiousness. Although we make every effort to ensure that the data and information are as correct and up-to-date as possible, we still cannot guarantee that they are free from mistakes and errors.

All information and data contained in this document are subject to alterations without prior notice. Distribution and reproduction of this document as well as the use and disclosure of its content is not authorized unless expressly approved. Offenders will be held liable for the payment of damages. All rights reserved in the case of a patent award or utility model registration.

Basically the General Terms and Conditions of **AUMÜLLER AUTOMATIC GmbH** apply to all offers, supplies and services.

The publication of these assembly and commissioning instructions supersedes all previous editions.

AUMÜLLER AUMATIC GMBH  
Gemeindewald 11  
86672 Thierhaupten

Tel. +49 8271 8185-0  
Fax +49 8271 8185-250  
info@aumueller-gmbh.de

**[www.aumueller-gmbh.de](http://www.aumueller-gmbh.de)**

9000000201\_V5.1\_KW24/22